

Hy-Pro Drive
Marine Steering Technology

sales@hypro.co.uk
+44 (0) 1626 863634



Marine Autopilot Hydraulic Steering Components

Hydraulics Engineering Quality and Manufacturing Excellence

Who are we?

Since 1967 Hydraulic Projects has been designing and manufacturing hydraulic marine autopilot steering equipment and hydraulic control valves from our UK base. With our own in-house design team using the latest 3d software and CNC machines, we control the complete process from initial concept through manufacture, assembly and test.

We guarantee the product is manufactured to the very highest quality and delivered on time.

What do we do?

We manufacture range of marine autopilot hydraulic steering equipment. Additionally, we produce a large range of hydraulic directional control valves supplemented by ancillary valves such as pilot check, service line relief's etc. We can also tailor our designs to suit your requirements.

Who are our customers?

Our marine equipment is used by the worlds leading autopilot manufacturers. You will find our valves on a vast range of equipment from recovery vehicles to refuse wagons, industrial jigs and fixtures, agricultural machinery, construction and plant equipment, boat winches and many other applications.

Now what do you do?

Just look through this catalogue or browse our web site – www.hypro.co.uk –for your Motion control requirements. Or call us to discuss your needs and we will be happy to help you choose the right product for your application.

So how can we help you?

Our contact details are shown on the back cover of this catalogue and our dedicated sales team are waiting to take your call.

Ordering

We are happy to accept orders by phone or email. Please use the catalogue order codes where possible. If you can't see what you want in the catalogue please contact us as our range goes beyond what is printed here. Please check and confirm availability of items before ordering.

Shipping

We use a national carrier for most orders or post for smaller items where appropriate. Alternatively you may arrange your own collection but there will be a small packing charge.

Payment

Payment can be made by credit/debit card or bank transfer. New accounts are strictly on a proforma basis. Credit accounts are available on application and subject to the usual credit checks.

Important information

Any samples or weights, measurements, capacities or other particulars contained in illustrations or descriptive material, including information contained in the Hydraulic Projects Ltd's brochures, website, advertising material or elsewhere, shall not form part of the contract and shall be treated as approximate and for guidance only unless specifically stated otherwise. Hydraulic Projects Ltd may at its discretion from time to time vary the design of the Goods from that advertised. The buyer shall be responsible to Hydraulic Projects Ltd for ensuring the accuracy of the terms of any order including any applicable specification and for giving Hydraulic Projects Ltd any necessary information relating to the Goods. Hydraulic Projects Ltd assumes no responsibility for ascertaining that the Goods are suitable and sufficient for the buyer's purposes.

This catalogue must not be reproduced (in whole or in part) without the prior written consent of Hydraulic Projects Ltd. This catalogue supersedes all previous issues.

A copy of our full terms and conditions is available on request or alternatively can be viewed or downloaded from our website.

Contents

PR+ Reversing Pumps.....	4
PR+ RX/X Pump With Relief Valves	6
PR+ RU Reversing Pump With Reservoir & Unloader.....	8
PR+RRV Reservoir Pump With Relief Valve	10
PR+ Spares and Accessories	14
PR+ Fitting Kits (Hose & Thread)	15
PC+ Constant Running Pump	16
PC Constant Running Pump	18
ML+40 Linear Actuator.....	22
Rudder Position Sensor	31
HS+40 Pre-filled Steering System.....	32
HS+50 Pre-Filled Steering System.....	34
HS+50 PC45 Pre-Filled Steering System Twin Cylinder...	36
R2254 Pilot Check Valve.....	38
R2345 Unloader Valve.....	40
R4306 Steering Fluid Reservoir.....	42
Spares & Accessories.....	43

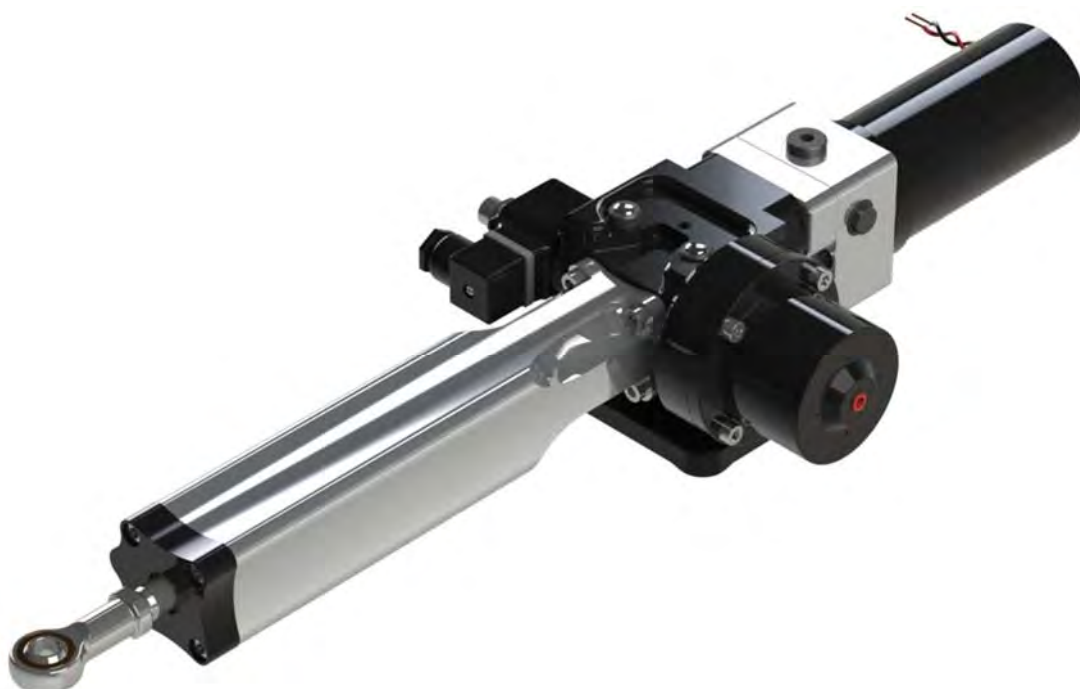

PR+ REVERSING ELECTRO-HYDRAULIC POWER UNIT

Backed with over 30 years of continuous development the new PR+ range of reversing pumps presents the ultimate in quiet and smooth operation. Unlike noisy piston pump designs the precision gear form delivers smooth flow in all conditions and with minimal noise. Now with IP67 motors that have a 4000 hour brush life these latest generation of Hy-ProDrive power units are the best available.



Description

A permanent magnet DC motor driven precision gear pump available with a range of flows from 0.6 to 2.5 L/ min. Each pump is fitted with zero-leakage pilot check valves for positive locking of steering cylinders.

The two service ports and reservoir port are positioned at the front of the pump. The threads are G1/4 (BSP) parallel. There is an optional second reservoir port on the top face accessed via a removable plug. If top mounted ports are preferred a kit is available to provide this option.

Relief valves to limit the maximum pressure generated are available as a further option.

The motors are maintenance free with internal brushes giving typically a 4000+ hour life. The front and rear bearings are sealed ball races for smooth and quiet operation. They have an Ingress Protection rating of IP67. They have a nominal output of 100W with a 50W option on the 12V PR+10 pumps.

The pumps are sealed on the driven gear journal allowing the motor to be removed without air entering or oil loss from the hydraulic circuit.

Application

Designed specifically for the marine autopilot market they are used by the worlds leading autopilot manufacturers. They can be used with balanced or unbalanced cylinders and are suitable for use in pressurized reservoir systems.

See page 13 for a selection guide for matching the drives to hydraulic steering cylinders.

Features

- Quiet and smooth operation
- Low power consumption.
- Zero back drive check valves.
- 6 flow options
- 100W motors
- 50W motor on PR+08
- 12V/24V DC motor options.
- Relief Valve option.
- Port position options.
- Compact.
- Easy installation.
- G1/4 (BSP) parallel ports
- NPTF and M10 adapter kits available
- Service kits available.
- Cylinders and hose kits supplied to suit.
- Fully compliant to the Recreational Craft Directive
- Supplied with EU Declaration of Conformity

Circuit Diagrams

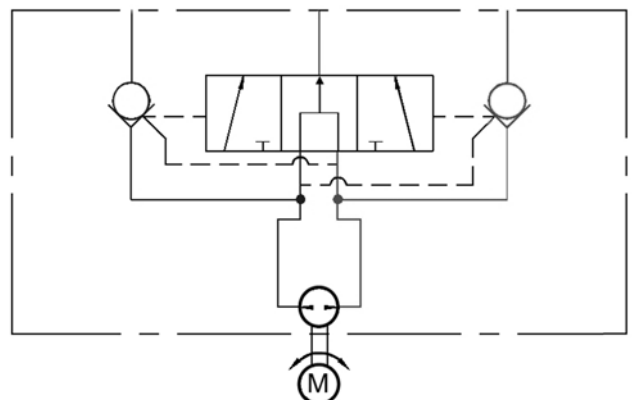

Technical data

Voltage	12V/24V DC			
Current	Typical amp-hour		Typical current	
	5 bar at 25% duty		Intermittent	
	12V	24V	12V	24V
PR+05 50W	1.5A	-	10.1A	-
PR+06 25W	0.9A	-	9.0A	-
PR+08 50W	1.3A	-	14.0A	-
PR+10 100W	2.2A	1.0A	19.0A	9.0A
PR+15 100W	2.4A	1.2A	24.0A	11.0A
PR+20 100W	2.5A	1.3A	25.0A	12.0A
PR+25 100W	2.7A	1.4A	34.0A	15.5A
Ingress protection	IP67			
EMC protection	BS EN 60945:2002 (DC)			
Ignition protection	BS EN ISO 8846:2017			
Ambient operating temperature	-15 to +55 deg C			
Max pressure reservoir line	55 bar (intermittent operation) 2 bar max			
Ports	G1/4 (BSPP) Parallel A = cylinder port B = cylinder port R = reservoir port			
Orientation	Red lead to positive - pressure to A port Black lead to positive - pressure to B port			
Hoses	Suitable for working pressure 55 bar. Minimum burst pressure 100 bar.			
Fluid	ISO VG10 to VG40 Hydraulic mineral fluid meeting ISO 6743-4 HV			
Weight	3.0 kg			

Order Code

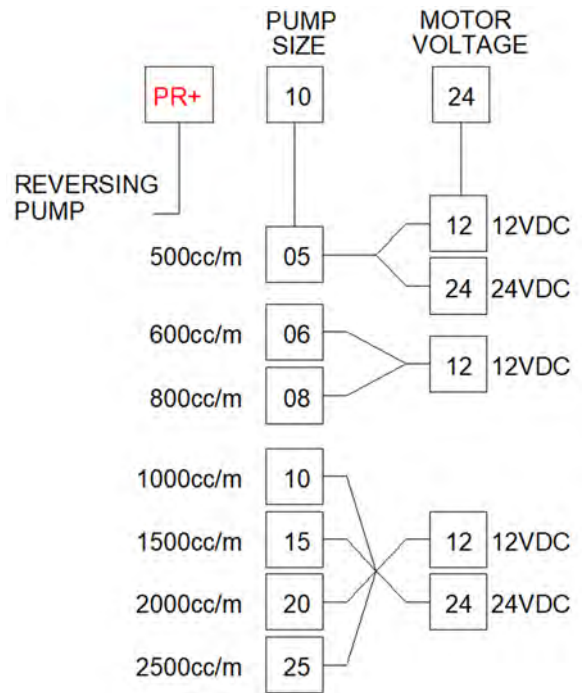

Installation Dimensions

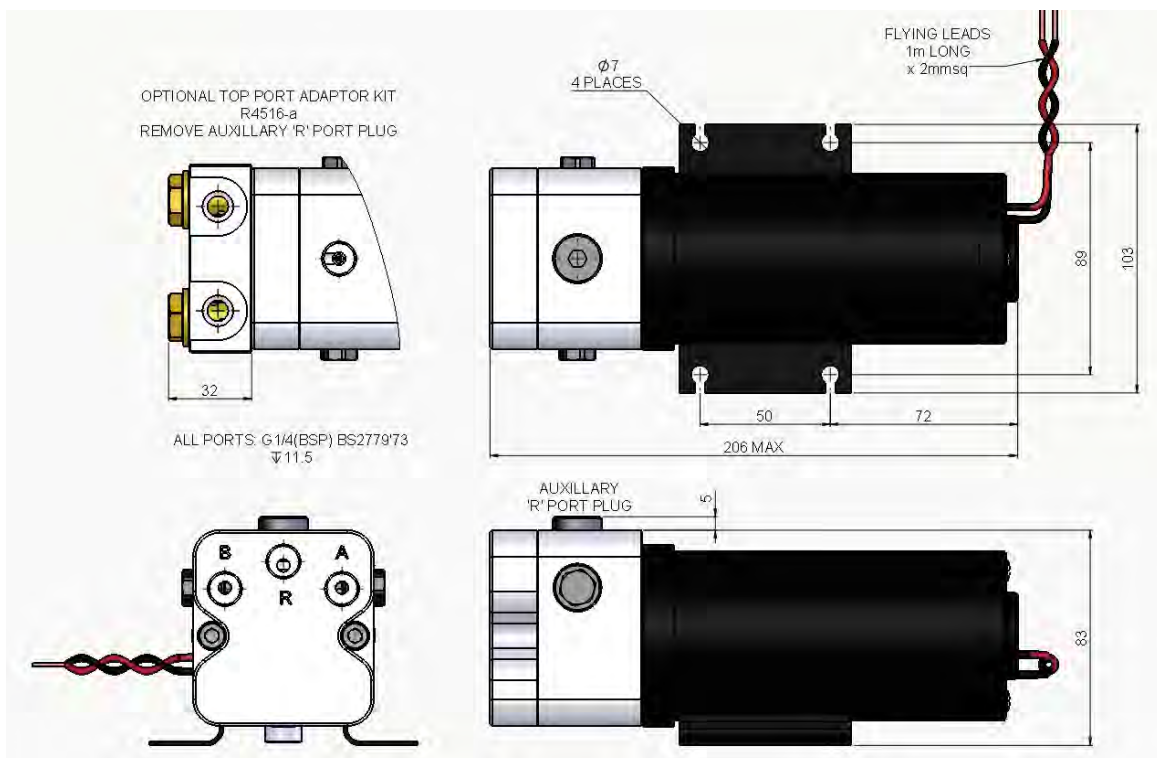

PR+ RX/X PUMP WITH RELIEF VALVES

The PR+ range of pumps is also available with relief valves which provide independent control of the maximum pressure available at each service port. Relief valves can be fitted to either 1 or both services. They are used in many applications worldwide including sports car suspension lifters, door and hatch openers and snow blowers.



Description

Utilising the standard PR+ pump and motor option, we have the addition of relief valve, to add to the versatility of the reversing pump range.

Complying with the small craft directives EMC and ignition requirements, this pump will have many onboard applications, that require load holding check valves.

In addition to Autopilot steering applications, the pump can be used in circuits requiring differing pressures for lifting and lowering. Hatch lifting, bathing platforms, gang planks etc

Application

This style of pump is suited to onboard applications requiring oil flows of 0.5 l/min to 2.5 l/min and pressures up to 55 bar. These will include auto pilot steering and hatch lifting.

It can also be used in automotive applications including suspension raising and hood lifting.

Features

- Independent relief valves on A & B ports
- Load holding check valves
- 6 Pump sizes
- 2 Motor sizes
- Adjustable relief valves
- IP67 1m rated motor
- Separate reservoir port
- Optional service port adaptors
- Optional reservoir available—Code R4306

Circuit Diagrams

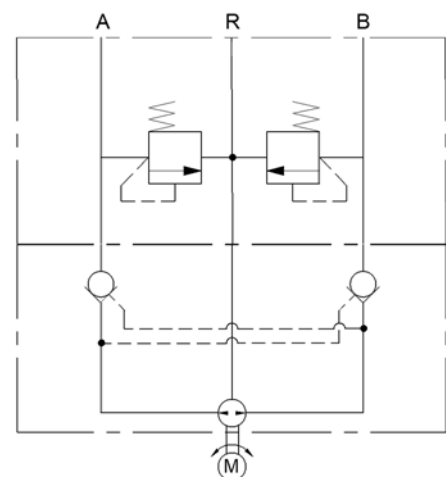

Technical data

Voltage	12V/24V DC			
Current	Typical amp-hour		Typical current	
	5 bar at 25% duty		Intermittent 55 bar max	
	12V	24V	12V	24V
PR+05 50W	1.5A	-	10.1A	-
PR+06 25W	0.9A	-	9.0A	-
PR+08 50W	1.3A	-	14.0A	-
PR+10 100W	2.2A	1.0A	19.0A	9.0A
PR+15 100W	2.4A	1.2A	24.0A	11.0A
PR+20 100W	2.5A	1.3A	25.0A	12.0A
PR+25 100W	2.7A	1.4A	34.0A	15.5A
Ingress protection	IP67			
EMC protection	BS EN 60945:2002 (DC)			
Ignition protection	BS EN ISO 8846:2017			
Ambient operating temperature	-15 to +55 deg C			
Max pressure reservoir line	55 bar (intermittent operation) 2 bar max			
Ports	G1/4 (BSPP) Parallel A = cylinder port B = cylinder port R = reservoir port			
Orientation	Red lead to positive - pressure to A port Black lead to positive - pressure to B port			
Hoses	Suitable for working pressure 55 bar. Minimum burst pressure 100 bar.			
Fluid	ISO VG10 to VG40 Hydraulic mineral fluid meeting ISO 6743-4 HV			
Weight	3.0 kg			
Port adaptor torque	27Nm (20 lb/ft)			

Order Code

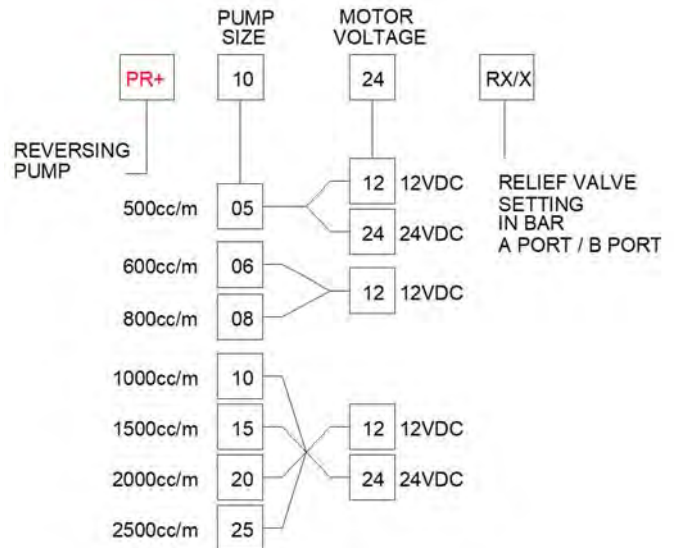

Installation Dimensions

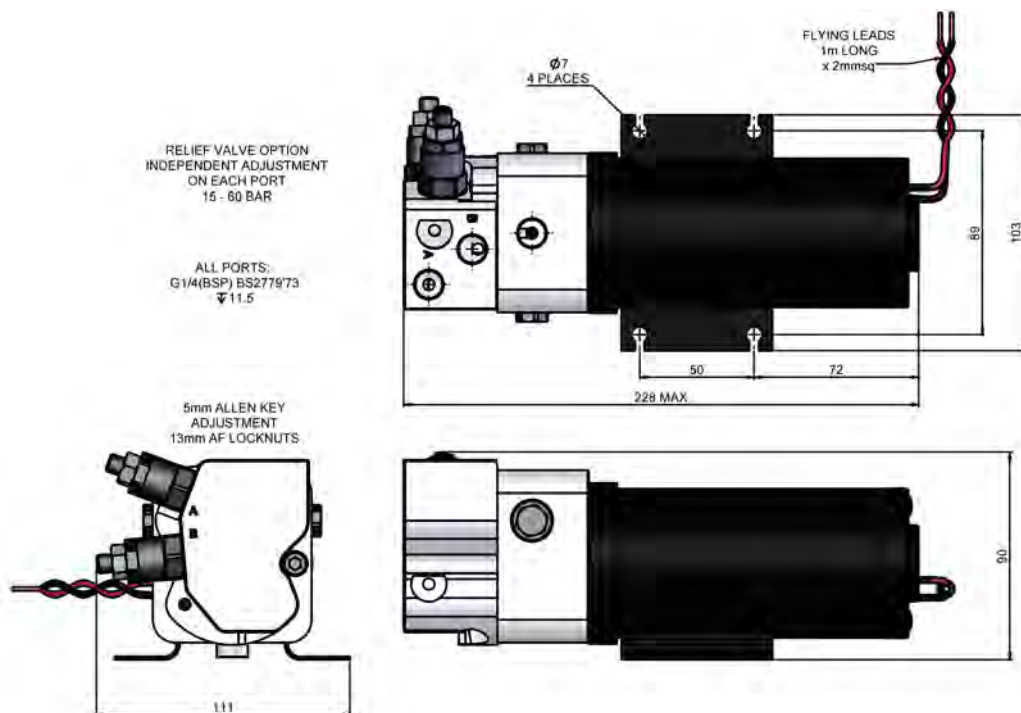

PR+ RU REVERSING ELECTRO-HYDRAULIC POWER UNIT WITH RESERVOIR AND SOLENOID UNLOADER

PR+ RU Reversing DC Hydraulic Power Unit with reservoir and clutch. Reversing type gear pumps driven by 12V/24V DC permanent magnet motors. Incorporated in the design are pilot operated check valves that prevent the pump being back driven by the manual steering system or rudder load. The motors have an IP67 rating and can be removed from the pump without allowing air into the hydraulic system or fluid to escape. They can be used with both balanced and unbalanced cylinders.

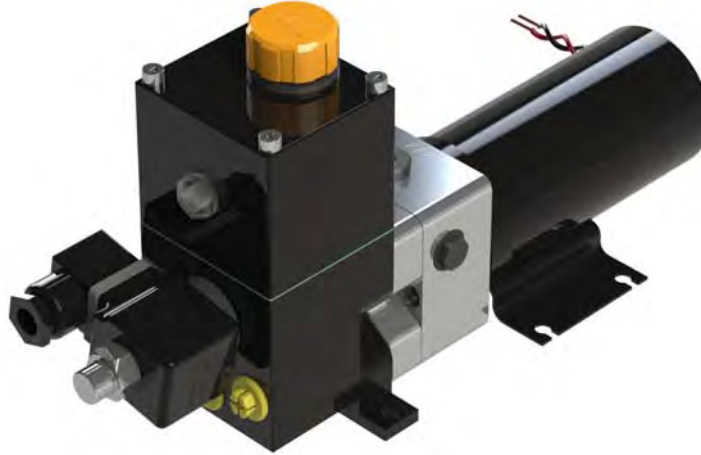

Description

The PR+RU incorporates the proven PR+ reversing pump and motor range but with an integral reservoir and solenoid unloader valve.

Complete with pilot check valves this compact unit can be used where the vessel has a mechanical primary steering and an autopilot stand-alone secondary hydraulic drive is required. With just two hose connections, uniquely the unit can be used with balanced or unbalanced cylinders*. The unloader solenoid coil is switched by the course computer clutch connection to engage and disengage the drive.

By design the very low back drive loads preserve the feel of the helm when steering by hand. The reservoir allows for extreme heel angles without any fluid loss and the IP67 motor and solenoid ensure no water ingress problems.

In the event of primary mechanical steering failure the system can be used as emergency steering with the autopilot.

Manufactured from corrosion resistant marine grade materials the unit can be easily serviced and the motor changed with just two bolts and no fluid loss or air ingress into the system.

With the option of omitting the unloader valve the unit can be used in other hydraulic applications such as hatch, window and bathing platforms with the check valves locking the hydraulic cylinder in place.

*maximum differential volume 50 cc.

Application

When connected to a secondary steering cylinder it forms a compact linear drive.

Features

- Quiet and smooth operation
- Low power consumption.
- Zero back drive check valves.
- 6 flow options
- 100W motors
- 50W motor on PR+08
- 25W motor on PR+06
- 12V/24V DC options.
- Compact size.
- Easy installation.
- External oil level indicator
- G1/4 (BSP) ports (with NPTF adapter kits available).
- Service kits available.
- Cylinders and hose kits supplied to suit.

Circuit Diagram

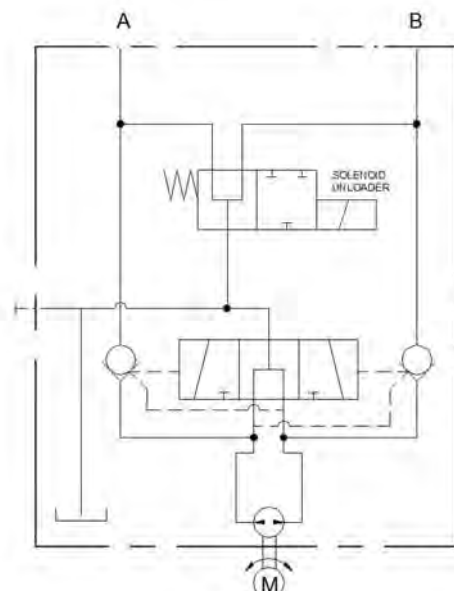

Technical data

Voltage	12V/24V DC			
Current	Typical amp-hour		Typical current	
	5 bar at 25% duty 55 bar max		Intermittent	
	12V	24V	12V	24V
PR+05 50W	1.5A	-	10.1A	-
PR+06 25W	0.9A	-	9.0A	-
PR+08 50W	1.3A	-	14.0A	-
PR+10 100W	2.2A	1.0A	19.0A	9.0A
PR+15 100W	2.4A	1.2A	24.0A	11.0A
PR+20 100W	2.5A	1.3A	25.0A	12.0A
PR+25 100W	2.7A	1.4A	34.0A	15.5A
Ingress protection	IP67			
EMC protection	BS EN 60945:2002 (DC)			
Ignition protection	BS EN ISO 8846:2017			
Ambient operating temperature	-15 to +55 deg C			
Max pressure reservoir line	55 bar (intermittent operation) 2 bar max			
Ports	G1/4 (BSPP) Parallel A = cylinder port B = cylinder port R = reservoir port			
Orientation	Red lead to positive - pressure to A port Black lead to positive - pressure to B port			
Hoses	Suitable for working pressure 55 bar. Minimum burst pressure 100 bar.			
Fluid	ISO VG10 to VG40 Hydraulic mineral fluid meeting ISO 6743-4 HV			
Weight	3.0 kg			

Order Code

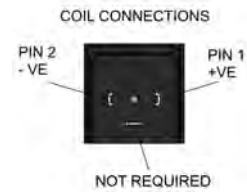
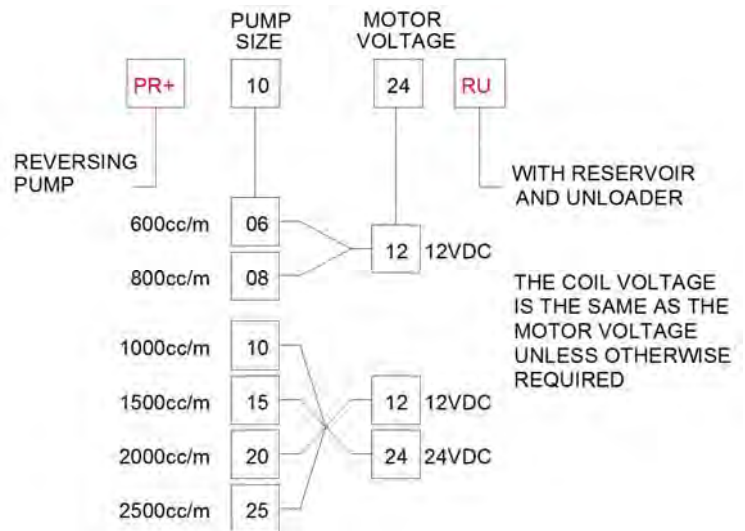

Installation Dimensions

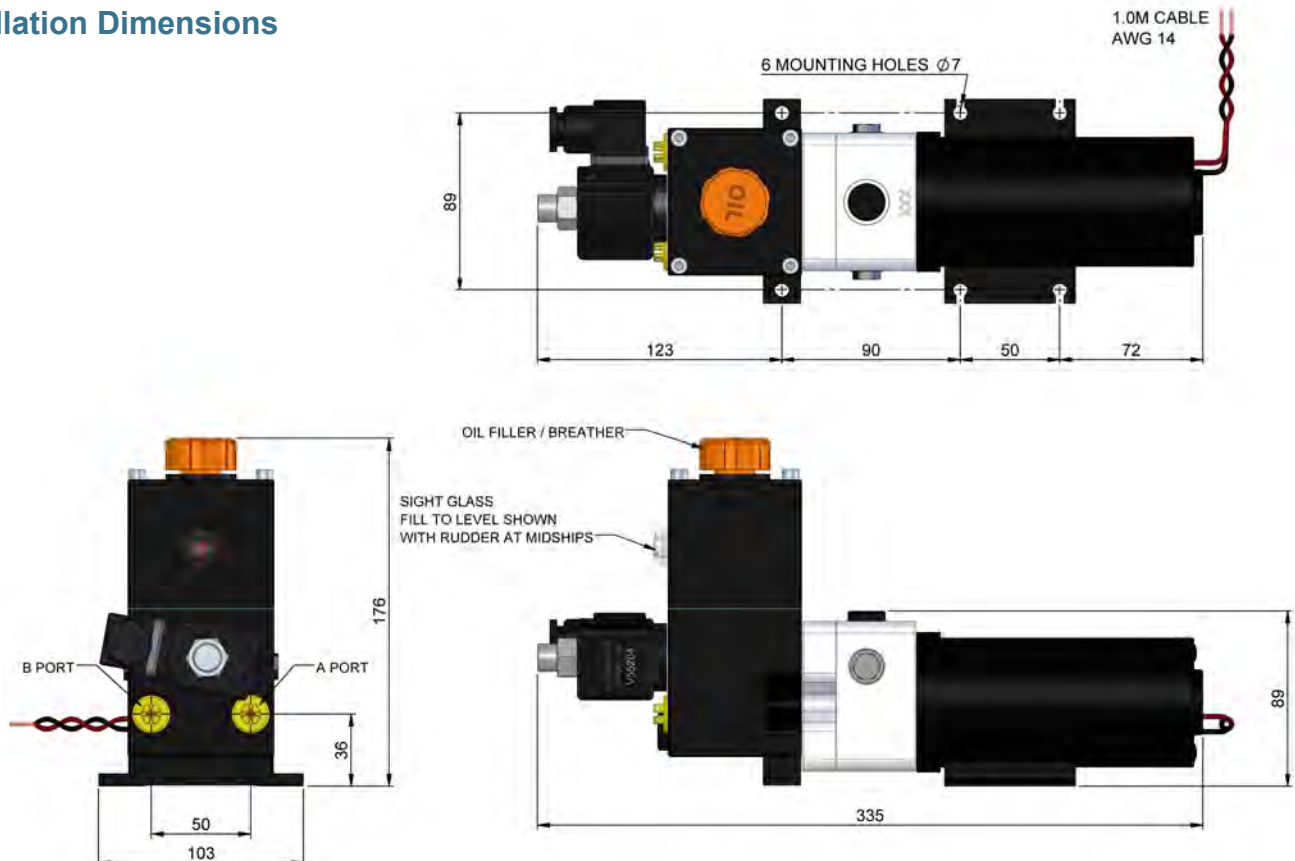

PR+ RRV REVERSING MARINE HYDRAULIC PUMP WITH RESERVOIR AND RELIEF VALVES

PR+ RRV Reversing DC Hydraulic Power Unit with reservoir and relief valves. Reversing type gear pumps driven by 12V/24V DC permanent magnet motors. Incorporated in the design are pilot operated check valves that prevent the pump being back driven by the manual steering system or rudder load. The motors have an IP67 rating and can be removed from the pump without allowing air into the hydraulic system or fluid to escape. They can be used with both balanced and unbalanced cylinders

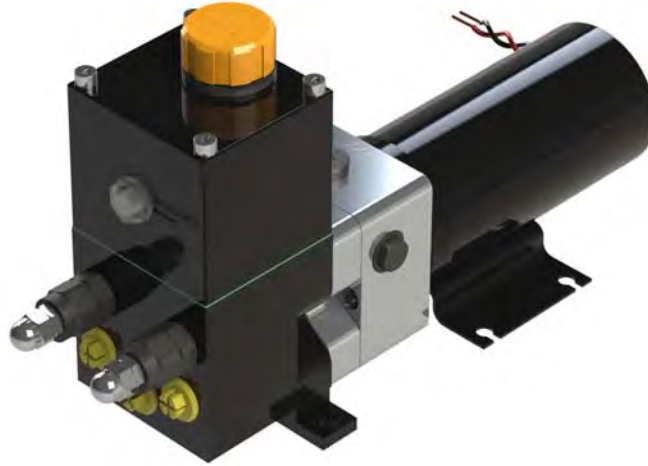

Description

"PR+RRV" reversing type gear pumps are driven by 12V/24V DC permanent magnet motors. Incorporated in the design are pilot operated check valves that prevent the pump being back driven by the manual steering system or rudder load.

The motors have an IP67 rating and can be removed from the pump without allowing air into the hydraulic system or fluid to escape. They can be used with both balanced and unbalanced cylinders. The pumps incorporate relief valves on each service port which allow the maximum pressure to be limited independently.

When used in conjunction with a cylinder of your choice, the PR+ RRV pump can be used for many onboard applications e.g. steering, hatch lifting, bathing platforms etc

Application

Designed specifically for the marine autopilot market they are used by the worlds leading autopilot manufacturers. They can be used with balanced or unbalanced cylinders and are suitable for use in pressurized reservoir systems.

See page 13 for a selection guide for matching the drives to hydraulic steering cylinders.

Features

- Quiet and smooth operation
- Low power consumption.
- Zero back drive check valves.
- 6 flow options
- 100W motors
- 50W motor on PR+08
- 12V/24V DC motor options.
- Relief Valve option.
- Port position options.
- Compact.
- Easy installation.
- G1/4 (BSP) parallel ports
- NPTF and M10 adapter kits available
- Service kits available.
- Cylinders and hose kits supplied to suit.
- Fully compliant to the Recreational Craft Directive
- Supplied with EU Declaration of Conformity

Circuit Diagram

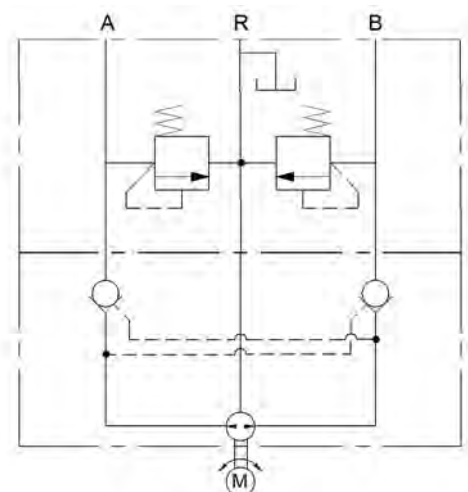

Technical data

Voltage	12V/24V DC			
Current	Typical amp-hour 5 bar at 25% duty		Typical current Intermittent 55 bar max	
	12V	24V	12V	24V
PR+RRV 05 50W	1.5A	-	10.1A	-
PR+RRV 06 25W	0.9A	-	9.0A	-
PR+RRV 08 50W	1.3A	-	14.0A	-
PR+RRV 10 100W	2.2A	1.0A	19.0A	9.0A
PR+RRV 15 100W	2.4A	1.2A	24.0A	11.0A
PR+RRV 20 100W	2.5A	1.3A	25.0A	12.0A
PR+RRV 25 100W	2.7A	1.4A	34.0A	15.5A
Ingress Protection	IP67			
EMC Protection	BS EN 60945:2002 (DC)			
Ignition protection	BS EN ISO 8846:2017			
Ambient operating Temperature	-15 to +55 deg C			
Max Pressure	55 bar (intermittent operation)			
Reservoir Capacity	107cc at midships			
Max heel Angle	60°			
Relief Valves	Adjustable between 15 and 60 Bar Adjustment rate per turn 30 bar Set at 50b unless otherwise stated			
Ingress Protection	IP67			
Reservoir Capacity	107cc at midships			
Max heel Angle	60°			
Ports	A = Cylinder port G1/4 (BSP) Parallel B = Cylinder port G1/4 (BSP) Parallel Filler / Breather G1/2 (BSP) Parallel			
Rotation	Red lead to positive - Pressure to A port			
Hoses	Suitable for working pressure 55 bar. Minimum burst pressure 100 bar.			
Fluid	SO VG10 to VG40 Hydraulic mineral fluid meeting ISO 6743-4 HV			

The following commercial fluids are suitable Fuchs Renolin B15 HV1 and Seastar HA5430

Installation Dimensions

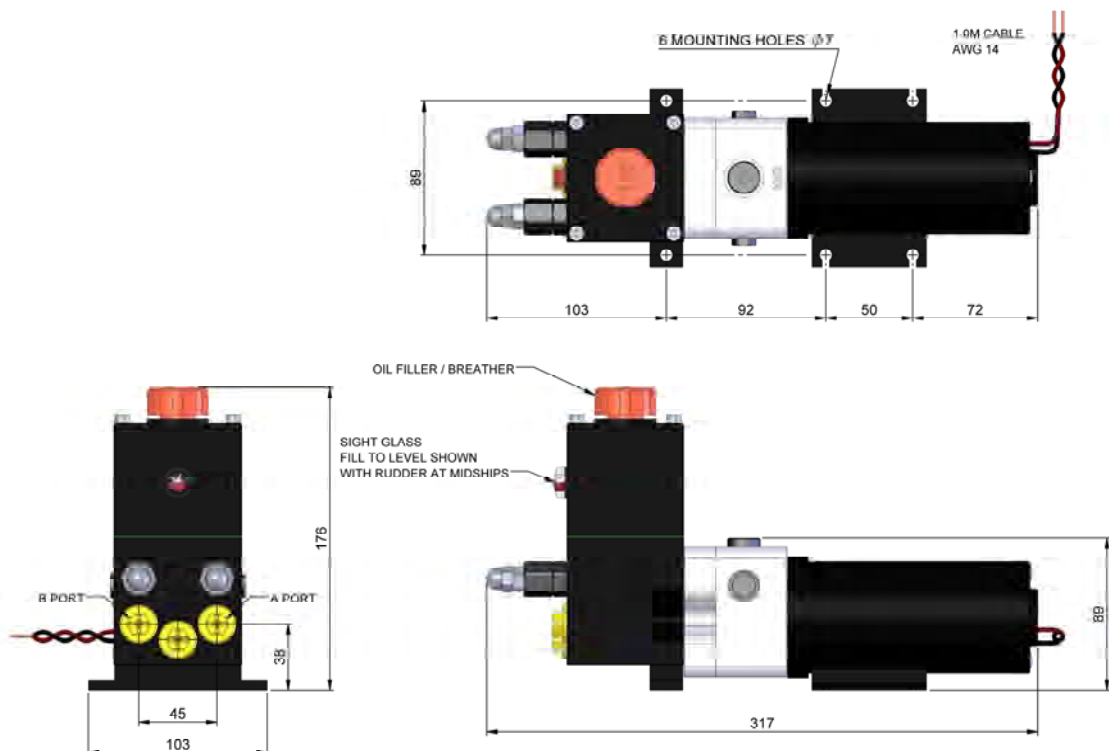

Order Code

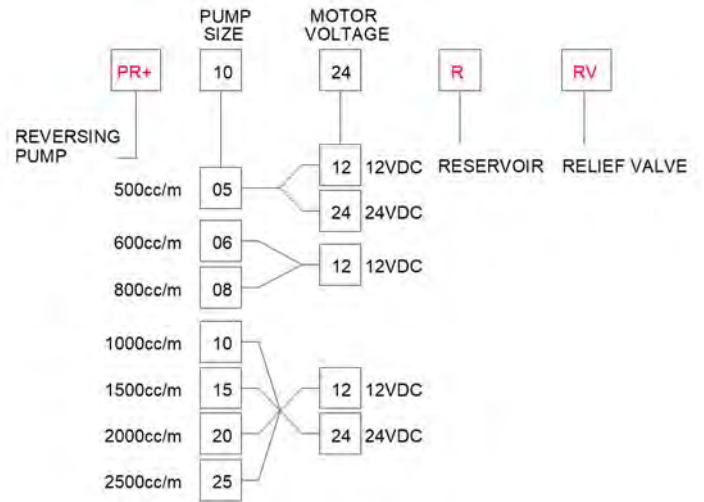

Performance Graph

Typical characteristics
Q8 Auto 15 oil @ 25°C

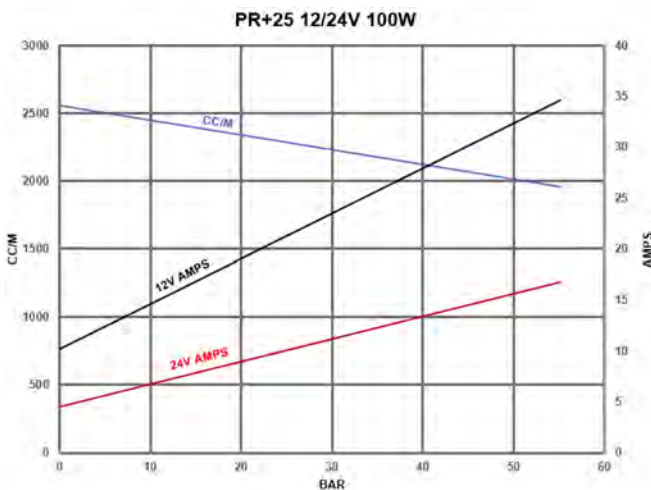
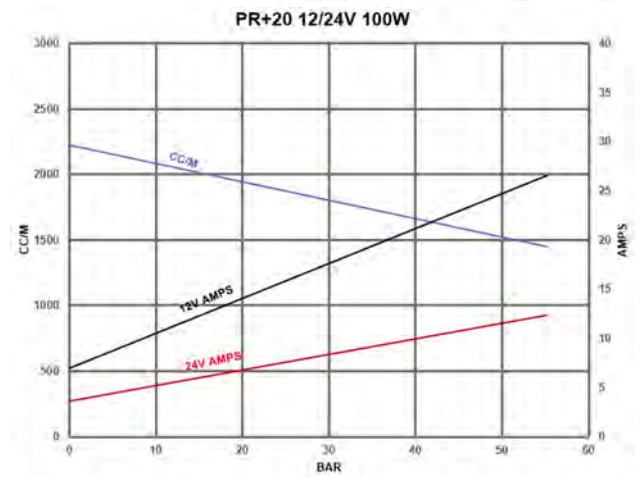
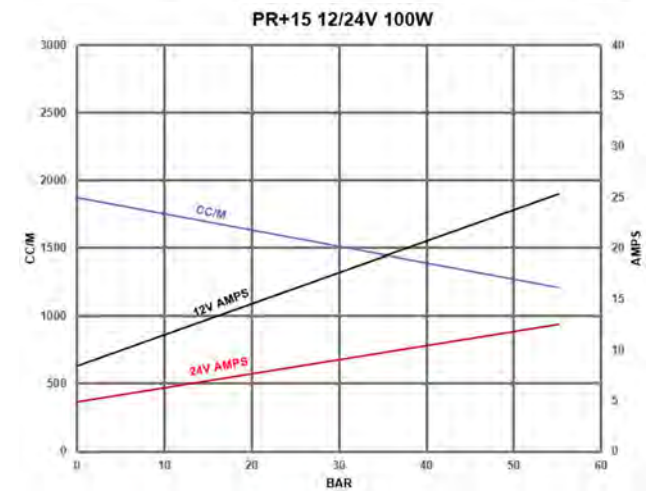
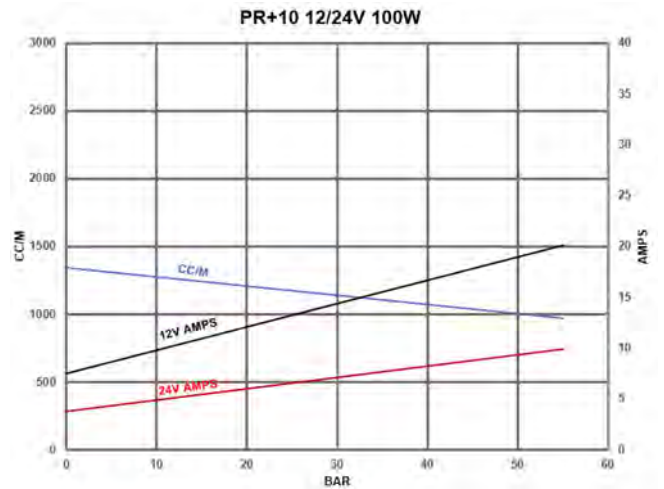
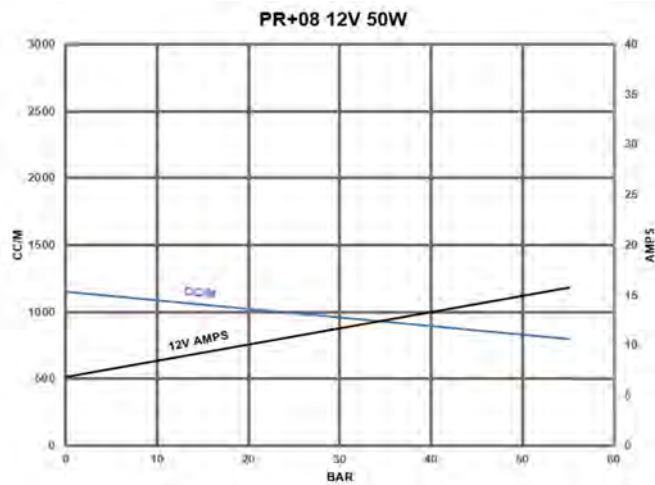
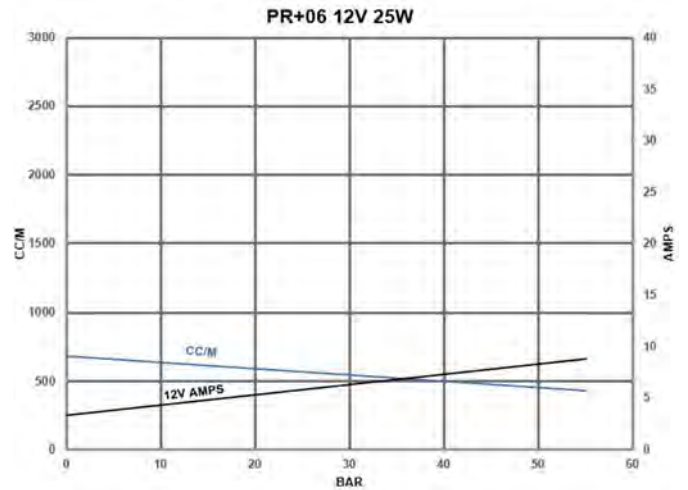
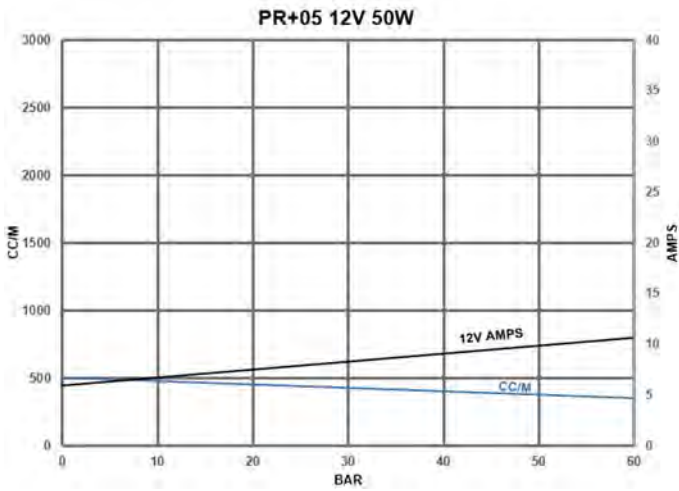

Did you know that our products are individually tested before despatch.

Drive Selection

It is important to select the correct size pump as it directly influences the ability of the autopilot to steer the vessel.

An autopilot drive will need to give a compatible Hard Over to Hard Over time to suit the vessel type (Or as specified by the autopilot manufacturer).

The HO to HO may be faster on lightweight planing craft / yachts and slower on displacement power boats / long keel or heavy yachts.

Note if the pump is too large, the vessel may over steer and will use more power, too small and the autopilot may struggle to maintain a course.

To use the table below you will need to know the volume of your steering cylinder. Select the HO to HO you require. Follow the column down until you approximately match your cylinder volume. Then select the pump on that row.

Note if your cylinder has a smaller volume, it will have a faster HO to HO. If it is larger, it will have a slower HO to HO.

“HO to HO” Is the time that the pump takes to drive the rudder from full port to full starboard. “Dock side” (no flow over the rudder).

Cylinder Volume (CC)	HARD OVER TIME (SECONDS)						
	6 to 8	8 to 10	10 to 12	12 to 14	14 to 16	16 to 18	18 to 20
50	PR+05						
75	PR+06	PR+05					
100	PR+08	PR+06	PR+05				
125	PR+10	PR+08	PR+06	PR+06	PR+05		
150	PR+15	PR+10	PR+08		PR+06	PR+05	
175	PR+15		PR+10	PR+08		PR+06	
200	PR+20	PR+15		PR+10	PR+08		PR+06
225	PR+20	PR+15		PR+10		PR+08	
250	PR+20		PR+15		PR+10		PR+08
275	PR+25	PR+20	PR+15			PR+10	
300	PR+25	PR+20		PR+15		PR+10	
325	PR+25	PR+20		PR+15			PR+10
350		PR+25	PR+20		PR+15		
375		PR+25	PR+20		PR+15		
400		PR+25	PR+20	PR+20		PR+15	
425			PR+25	PR+20		PR+15	
450			PR+25	PR+20			PR+15
475			PR+25		PR+20		PR+15
500				PR+25	PR+20		
525				PR+25	PR+20		
550				PR+25		PR+20	
575				PR+25		PR+20	
600					PR+25	PR+20	
625					PR+25		PR+20
650					PR+25		PR+20
675						PR+25	
700						PR+25	
725						PR+25	
750							PR+25

Spares and Accessories

Replacement Motor Kits

The motors fitted to the PR+, ML+40 and HS+ systems are rated to IP67 and sealed for life*. When the time comes for replacement the complete motor is changed. They can be replaced in-situ with no loss of oil or allowing air into the system. The kits come complete with spare face seal, coupling and bolts.

* 4000+ hours in average use.



Order Code

R4510-sk 12 100	PR+05 12	HS+40 10 12
	PR+10 12	
	PR+15 12	
	PR+20 12	HS+40 20 12
	PR+25 12	HS+50 25 12

R4510-sk 12 100 X	ML+40 10 12
	ML+40 20 12

R4510-sk 24 100	PR+05 24	HS+40 10 24
	PR+10 24	
	PR+15 24	
	PR+20 24	HS+40 20 24
	PR+25 24	HS+50 25 24

R4510-sk 24 100 X	ML+40 10 24
	ML+40 20 24

R4510-sk 12 25	PR+06 12
-----------------------	----------

PR+ Top Port Adaptor Kit

Where space is limited or when replacing an existing top ported pump an easy-fit adaptor kit is available for the Hy-ProDrive PR+ pump range. The kit fits all sizes of PR+ reversing pump.

Order Code

R4516

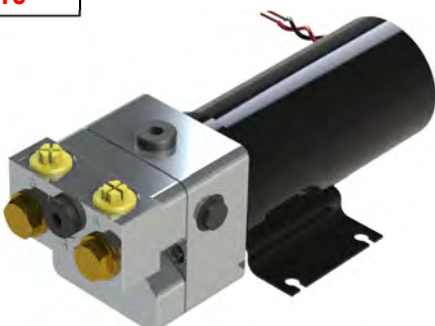

Hydraulic Fitting Kits for Reversing Pumps

To facilitate simple installation of reversing pumps, Hy-ProDrive offer a range of fittings to accommodate many hose/thread sizes. Each kit consists of 3 pump fittings and seals.

Thread size

Part No:

1/4 BSP
G1/4 to G1/4

R2377-14



3/8 BSP
G1/4 to G3/8

R2377-38



5/8 SAE
G1/4 to G5/8 SAE

R2377-58



5/8 SAE Elbow
G1/4 to G5/8 SAE

R2377-58E



1/4 NPTF
G1/4 to 1/4 NPTF

R2377-N



10mm Pipe
G1/4 to 10mm pipe
(With Olive)

R2377-10P



3/8" Pipe
G1/4 to 3/8 pipe
(With Olive)

R2377-38P



9/16 ORB
G1/4 to 9/16 ORB

R2377-916ORB



9/16 Ultraflex hose
G1/4 to 9/16 24

R2377-916UNEF



PC+ CONSTANT RUNNING PUMP

The Hy-ProDrive constant running pumps are designed to operate a boats steering mechanism, as part of a marine autopilot system. Typically used in commercial applications.

The PC+10 and PC+15 have been introduced to the constant running pump portfolio, offering flow rates of 1.0L/min and 1.5L/min.

These smaller pumps are ideally suited for smaller catamaran vessels within the fishing industry, with steering cylinder capacities of 150cc to 400cc.

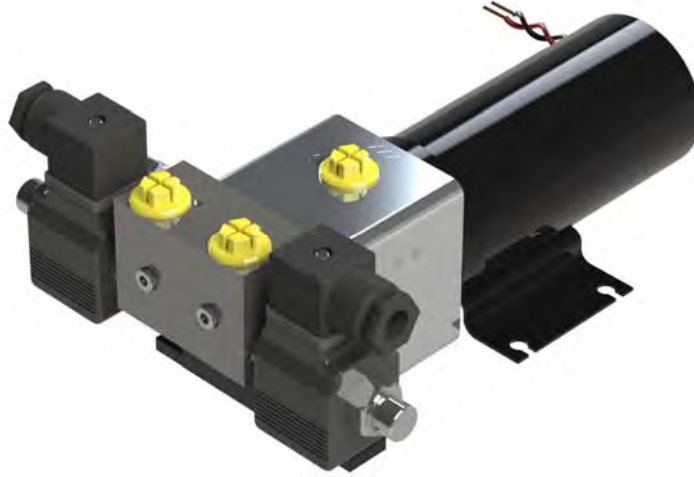

Description

The "PC+" constant running type gear pumps are driven by 12V/24V DC permanent magnet motors. Flow reversal is achieved by switching a double acting solenoid valve. Incorporated in the design are pilot operated check valves that prevent the pump being back driven by the manual steering system.

Other features include compatibility with balanced or unbalanced cylinders and they can also be used with pressurised reservoir systems (max 3.5 bar).

An adjustable relief valve is fitted as standard.

Maximum flow output at no load is indicated on the rating plate. Check the voltage shown is correct for the output of your autopilot.

Application

A compact constant running hydraulic pump, for use with and autopilot pilot system, to steer smaller commercial craft.

Typically used on catamaran fishing and work boats, with inboard or outboard engines.



Features

- 1.0 or 1.5 L/min nominal flow
- 12V/24V DC 100W constant running motor
- Solenoid directional control valve
- Zero leakage check valves
- Integral relief valve
- IP67 rating (IP65 solenoid connectors)
- Suitable for cylinders 150cc to 400cc
- Manufactured in the UK

Circuit Diagram

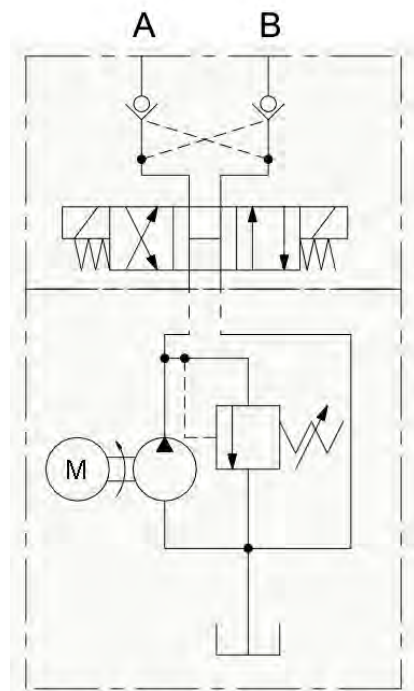

Technical data

Weight: 5 kg

Finish: Motor - black enamel
Pump: Clear anodised
Solenoid manifold: Black paint to HTS1006

Ports: G1/4 (BSPP) BS2779'73

Motor: 12V DC or 24V DC 100W

Solenoids: 12V DC or 24V DC 24W

Nominal Pump output:

PC+10	1.0 L/min
PC+15	1.5 L/min

Relief Valve Set 55 Bar

IP Rating: Pump & Coils: IP67
Connectors: IP65

EMC Protection BS EN 60945:2002 (DC)

Ignition Protection: BS EN ISO 8846:2017

Location: Under deck, dry compartment only

Orientation: Horizontal or Vertical motor up

Rotation: Red lead to positive

Hoses: Suitable for working pressure 70 bar.
Minimum burst pressure 100 bar.

Fluid: ISO VG10 to VG40 Hydraulic mineral fluid meeting ISO 6743-4 HV
The following commercial fluids are suitable.
Fuchs Renolin B15 HV1
Seastar HA5430

Performance Graph

Typical characteristics
Q8 Auto 15 oil @ 25°C

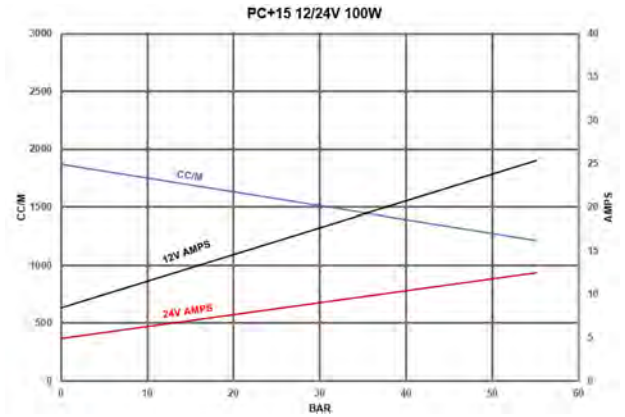
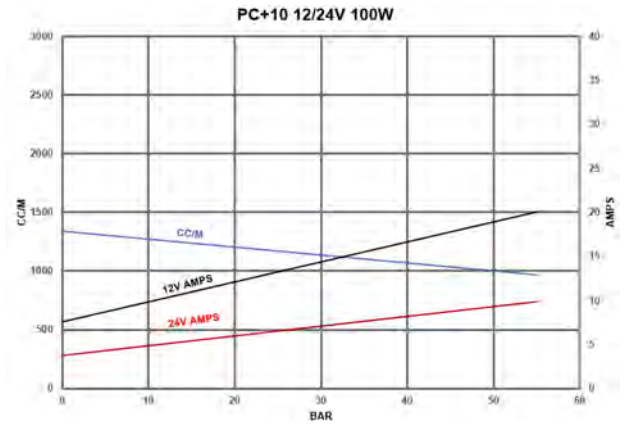

Order Code

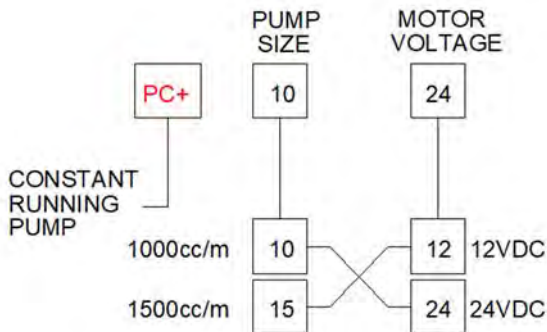

Installation Dimensions

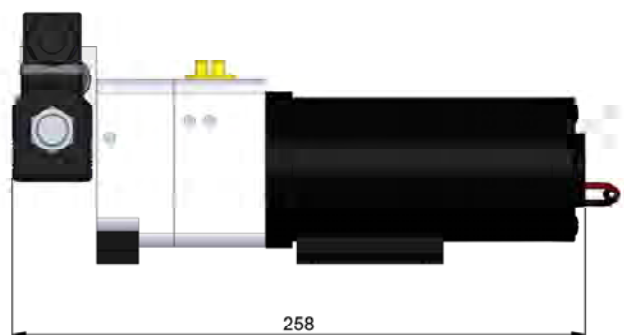
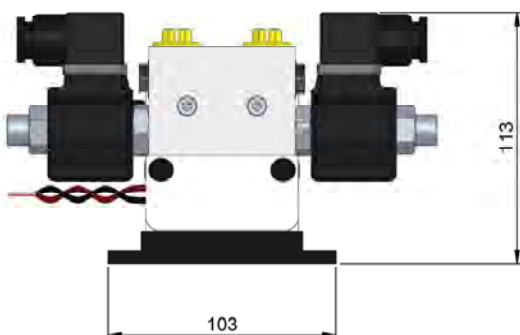
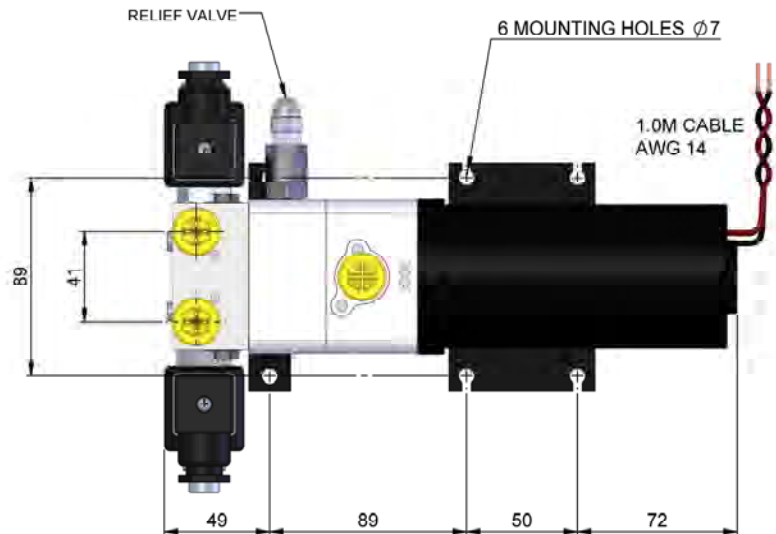

PC CONSTANT RUNNING ELECTRO-HYDRAULIC POWER UNIT

Manufactured specifically for marine autopilot steering applications the versatile PC constant running power units use a heavy-duty fan cooled motor coupled to optional pump sizes to deliver up to 4.5 L/min. Designed to be used for heavy duty applications on diesel powered vessels or commercial craft these units come fitted with pressure compensated flow controls, relief valve and cylinder check valves as standard.

Description

Once the hard-over time has been set via the speed control, the steering action is achieved by switching a damped heavy duty double acting solenoid valve. The motor and precision gear pump are protected by a pre-set relief valve, and check valves with toughened components positively lock the steering on course. A stainless steel clamp retains the stove enameled steel oil reservoir, and inside is a large capacity replaceable 15 micron return line filter to maintain system cleanliness. A heavy duty motor starting relay is also supplied, as are the rubber noise absorbing mounts.

Application

Designed and developed specifically for marine autopilot applications in the commercial boat market the PC can be used with single or twin ram systems. The design of the unit also makes it compatible with unbalanced rams and pressurized reservoir type systems.

Features

- Heavy duty fan cooled motor
- 12V/24V DC options.
- Low power consumption.
- Flow output options
- Integral speed control
- Integral relief valve
- Quiet operation.
- Compact construction.
- Replaceable brushes.
- Service kits.
- Easy installation.
- Cylinder and hose kits supplied to suit.
- Industrial Spec. Motor Relay included.
- EMC protection

Circuit Diagram

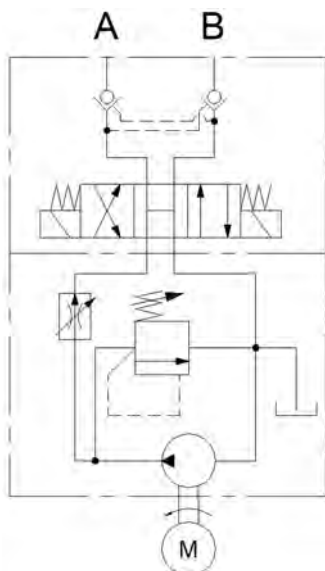

Technical Data

Voltage	12V/24V DC	
Pump output	Refer order codes.	
Ambient operating temperature	-15 to +55 deg C	
Motor voltage nominal	12V DC	24V DC
Motor output watts	405W	440W
Max continuous current	24A	12.5A
Ingress protection	IP44	
(Suitable only for 'under-deck', dry environment mounting.)		
EMC protection	BS EN 60945:2002 (DC) Line mounted	
Relief valve setting	58 bar	
Orientation	Solenoid A Pump to A port Solenoid B Pump to B port	
Coils	12V/24V DC 31W	
Coil connection	DIN 43650 (6-8mm cable)	
Relay Coil	12V/24V 12W	
Relay Rating	80A	
Fluid	ISO VG10 to VG40 hydraulic mineral fluid to ISO 6743-4 HV	
Reservoir capacity	4 litres	
Reservoir max pressure	3.5 bar max	
Weight	12 kg	

Installation Details



Performance Graphs
 Typical Performance
 ATF (40 cSt @40°C) @ 25°C

Order Code

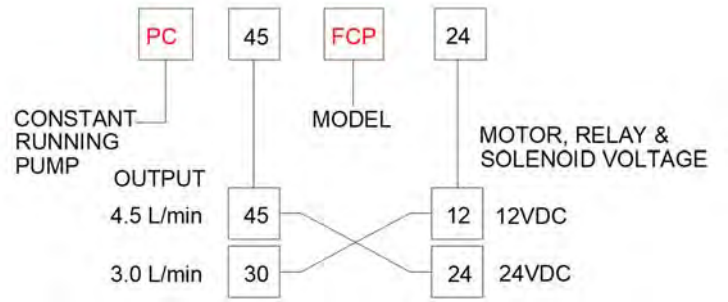
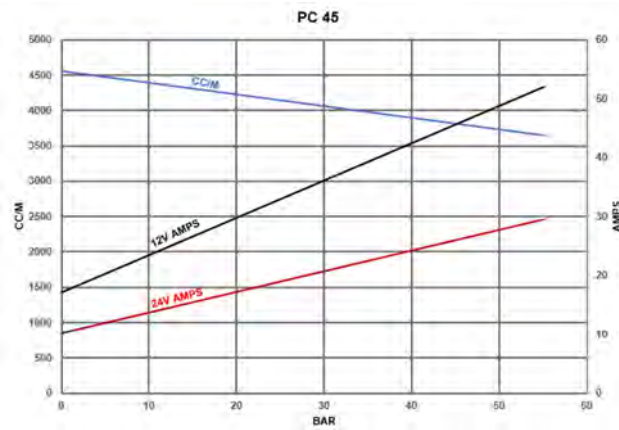
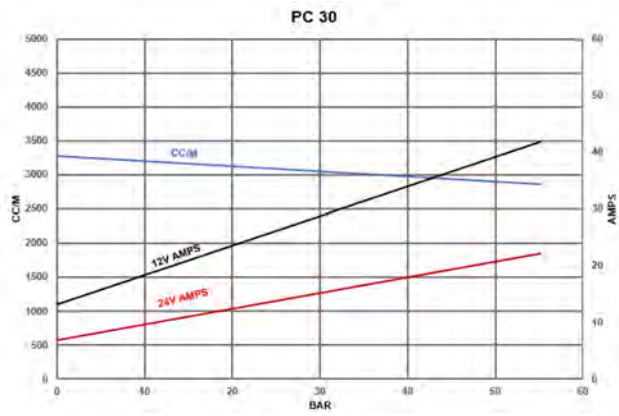

Drive Selection

It is important to select the correct size pump as it directly influences the ability of the autopilot to steer the vessel.

An autopilot drive will need to give a compatible Hard Over to Hard Over time to suit the vessel type (Or as specified by the autopilot manufacturer).

The HO to HO may be faster on lightweight planing craft and slower on displacement power boats.

Note if the pump is too large, the vessel may over steer and will use more power, too small and the autopilot may struggle to maintain a course.

To use the table below you will need to know the volume of your steering cylinder. Select the HO to HO you require. Follow the column down until you approximately match your cylinder volume. Then select the pump on that row.

Note if your cylinder has a smaller volume, it will have a faster HO to HO. If it is larger, it will have a slower HO to HO.

“HO to HO” Is the time that the pump takes to drive the rudder from full port to full starboard. “Dock side” (no flow over the rudder).

Cylinder

Volume

(CC)	HARD OVER TIME (SECONDS)						
	6 to 8	8 to 10	10 to 12	12 to 14	14 to 16	16 to 18	18 to 20
100	PC+10						
150		PC+10					
200	PC+15		PC+10				
250		PC+15		PC+10			
300	PC30		PC+15		PC+10		
350				PC+15			
400	PC45	PC30			PC+15		
500	PC45		PC30				
600	PC45		PC30				
700		PC45			PC30		
800			PC45		PC30		
900			PC45			PC30	
1000				PC45			PC30
1100					PC45		
1200						PC45	
1300						PC45	
1400							PC45
1500							PC45

ML+40 ELECTRO-HYDRAULIC SECONDARY STEERING LINEAR ACTUATOR

The ML+40 Electro Hydraulic Linear Actuator combines all the elements of a hydraulic circuit in one compact unit. Designed for ease of installation, the unit is supplied with a quick release mounting, tiller bolt and fitting kit. An optional rudder reference/feedback unit can be mounted directly onto the actuator. Integral relief valves protect the unit and its mountings from being overloaded.

Available in 3 stroke lengths 200mm, 250mm & 300mm



Description

The ML+40 combines a hydraulic cylinder, pump, IP67 motor, clutch and reservoir in one powerful and compact unit. To operate the clutch is engaged and the cylinder extends and retracts by means of reversing the motor polarity. Integral relief valves protect the unit and its mounting from rudder strikes etc. and anti-cavitation valves are also incorporated to allow full stroke speeds of up to 2 seconds when back-driven by the helm.

Designed for ease of servicing the motor can be removed from the unit without affecting the hydraulic circuit.

A full range of spares, seal kits and servicing tools are available.

The ML+40 is supplied pre-filled and ready to install.

Application

Ruggedly designed specifically for the marine auto-pilot market, they are widely used on sailboats and power craft with displacement or fast planing hulls. They are ideal where space is limited as there is no separate pipe-work or reservoirs to fit. The unit can be mounted in any attitude.

Sensor Order Code See page 31

R4660-a



Features

- 3 Stroke lengths 200mm, 250mm & 300mm
 - Ease of installation
 - Low profile
 - Low power consumption.
 - IP67 motors
 - EMC protection
 - Ignition protection
 - 2 speed options
 - Integral relief valves
 - Low maintenance
 - Quick release mounting
 - 12V/24V DC option
 - Service kits available
 - Low back-drive
 - Marine environment protective finish
 - User serviceable
 - Spares kits available
 - Optional remote reservoir
- BS EN 60945:2002 (DC)
BS EN ISO 8846:2017

Order Code

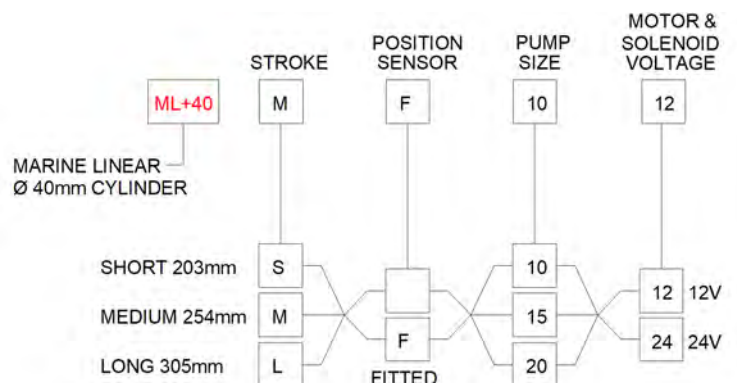

OTHER OPTIONS ARE AVAILABLE
PLEASE CONTACT US FOR DETAILS

Technical Data

Ram Stroke Part Number	Voltage V DC/W	Stroke Sec	Max Thrust Kg	Max Torque Nm	Tiller arm 70° mm	650Kg Amp
200mm						
ML+40 S 15 12	12/50	12	350	600	175	na
ML+40 S 10 12	12/100	10	703	1200	175	19.0
ML+40 S 10 24	24/100	10	703	1200	175	9.0
250mm						
ML+40 M 10 12	12/100	13	703	1470	213	19.0
ML+40 M 10 24	24/100	13	703	1470	213	9.0
ML+40 M 20 12	12/100	9	703	1470	213	25.0
ML+40 M 20 24	24/100	9	703	1470	213	12.0
300mm						
ML+40 L 20 12	12/100	11	703	1770	257	25.0
ML+40 L 20 24	24/100	11	703	1770	257	12.0
ML+40 L 25 12	12/100	9	703	1770	257	32.0
ML+40 L 25 24	24/100	9	703	1770	257	16.0

Ram Stroke Part Number	60Kg 25% Duty Ah	Relief set Bar	Clutch Watts	Weight Kg	Feedback Resistance kΩ
200mm					
ML+40 S 15 12	1.3	62	12	7.5	1.2
ML+40 S 10 12	2.0	62	12	7.5	1.2
ML+40 S 10 24	1.0	62	12	7.5	1.2
250mm					
ML+40 M 10 12	2.0	62	12	8.0	1.2
ML+40 M 10 24	1.0	62	12	8.0	1.2
ML+40 M 20 12	2.5	62	12	8.0	1.2
ML+40 M 20 24	1.3	62	12	8.0	1.2
300mm					
ML+40 L 20 12	2.5	62	12	8.5	1.2
ML+40 L 20 24	1.3	62	12	8.5	1.2
ML+40 L 25 12	3.0	62	12	8.5	1.2
ML+40 L 25 24	1.6	62	12	8.5	1.2

Installation

ML+40 S 10 (200mm stroke)
ML+40 S 15 (200mm stroke)

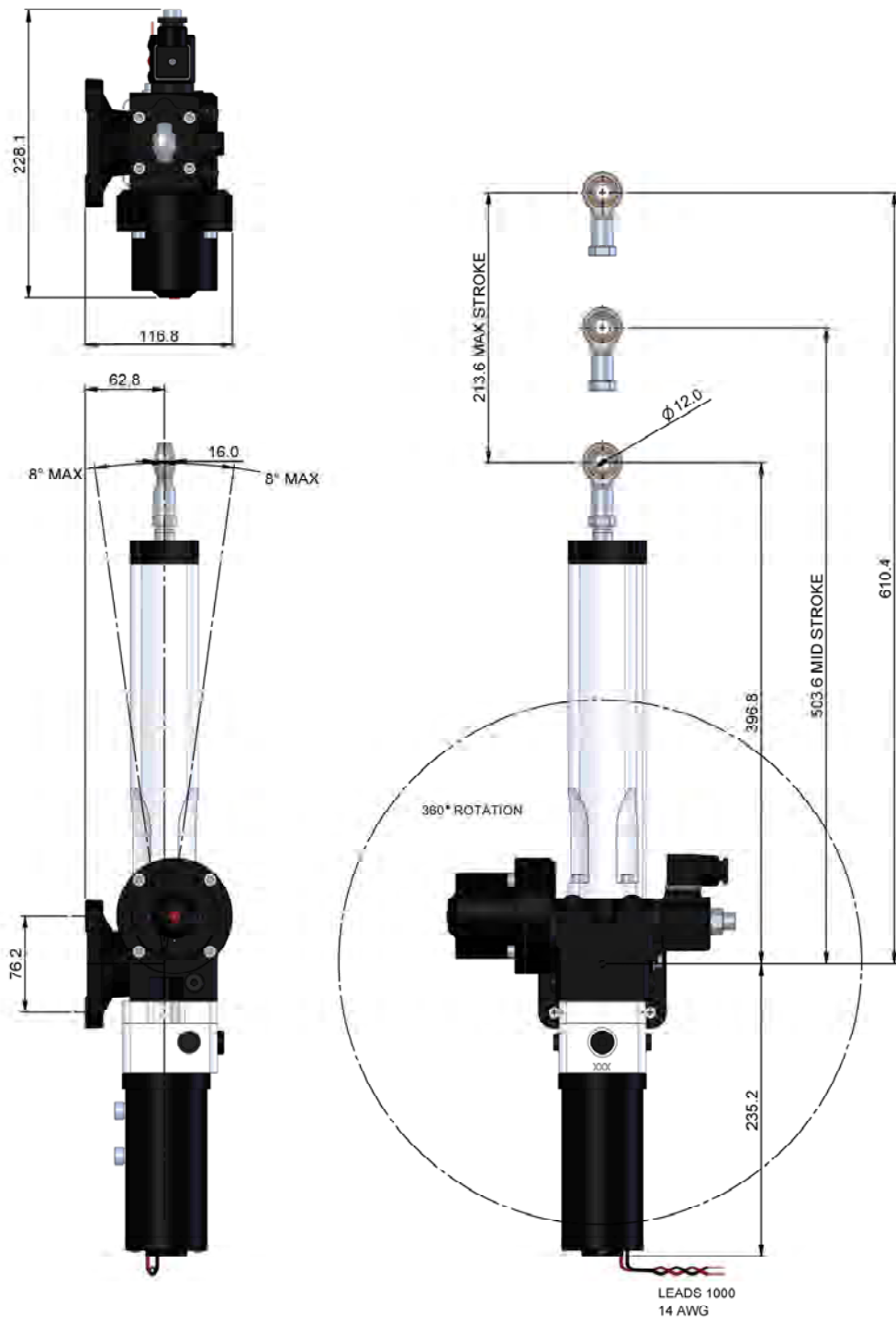

Quadrant

ML+40 S 10 (200mm stroke)

ML+40 S 15 (200mm stroke)

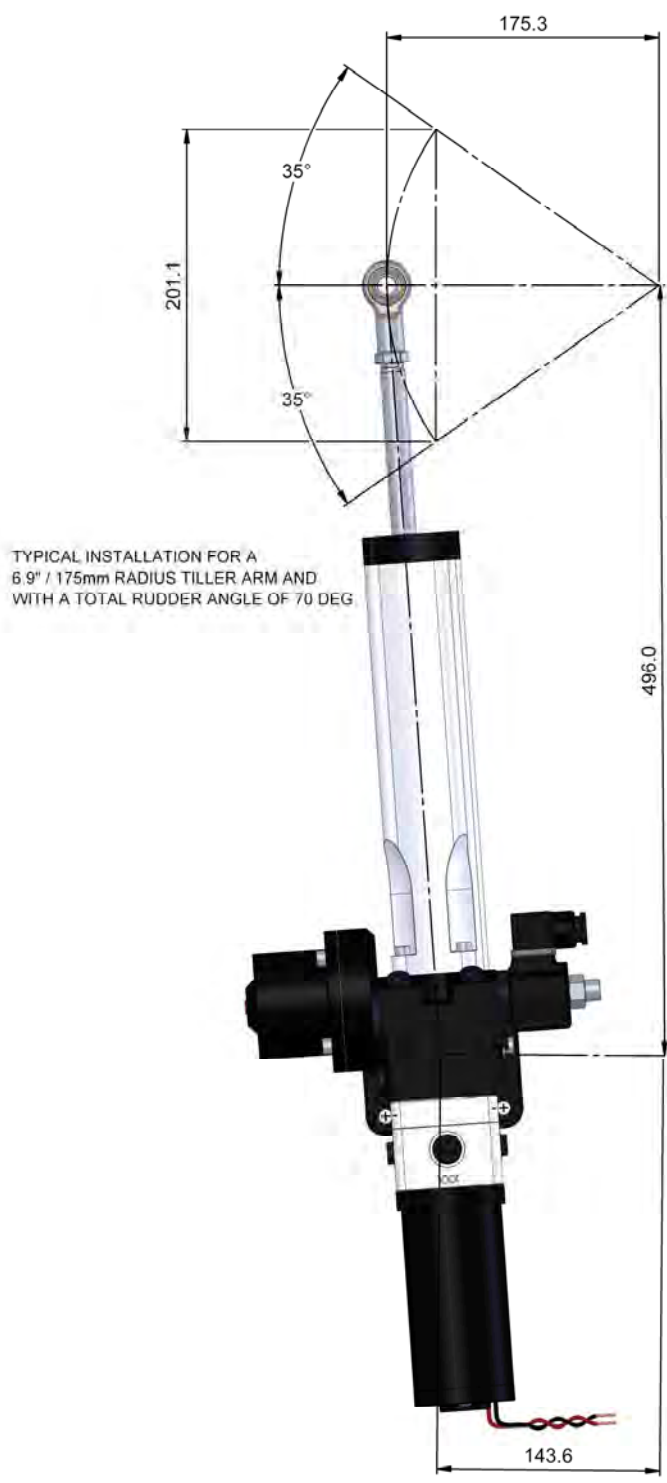

Installation

ML+40 M 10 (250mm stroke)
ML+40 M 20 (250mm stroke)

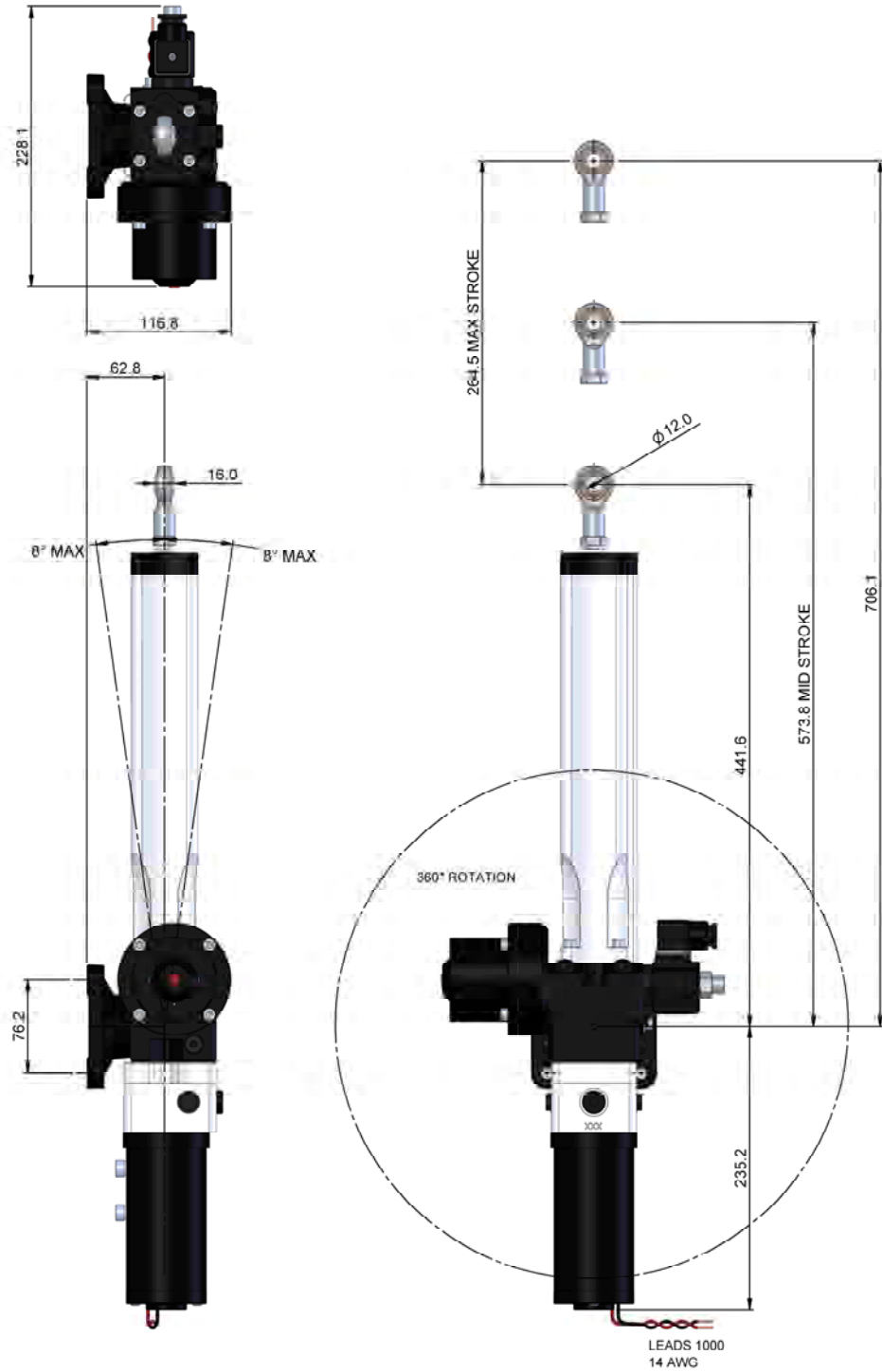

Quadrant

ML+40 M 10 (250mm stroke)
ML+40 M 20 (250mm stroke)

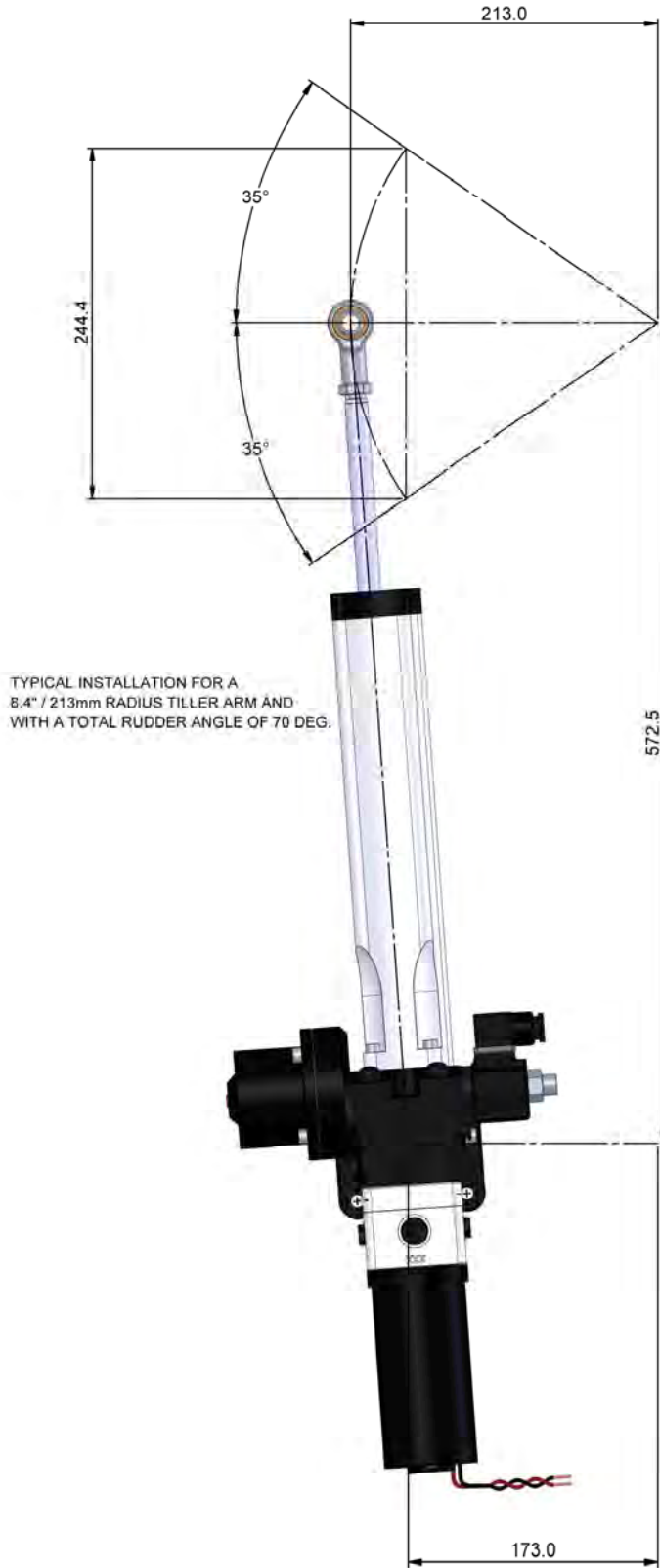

Installation

ML+40 L 10 (300mm stroke)
ML+40 L 20 (300mm stroke)

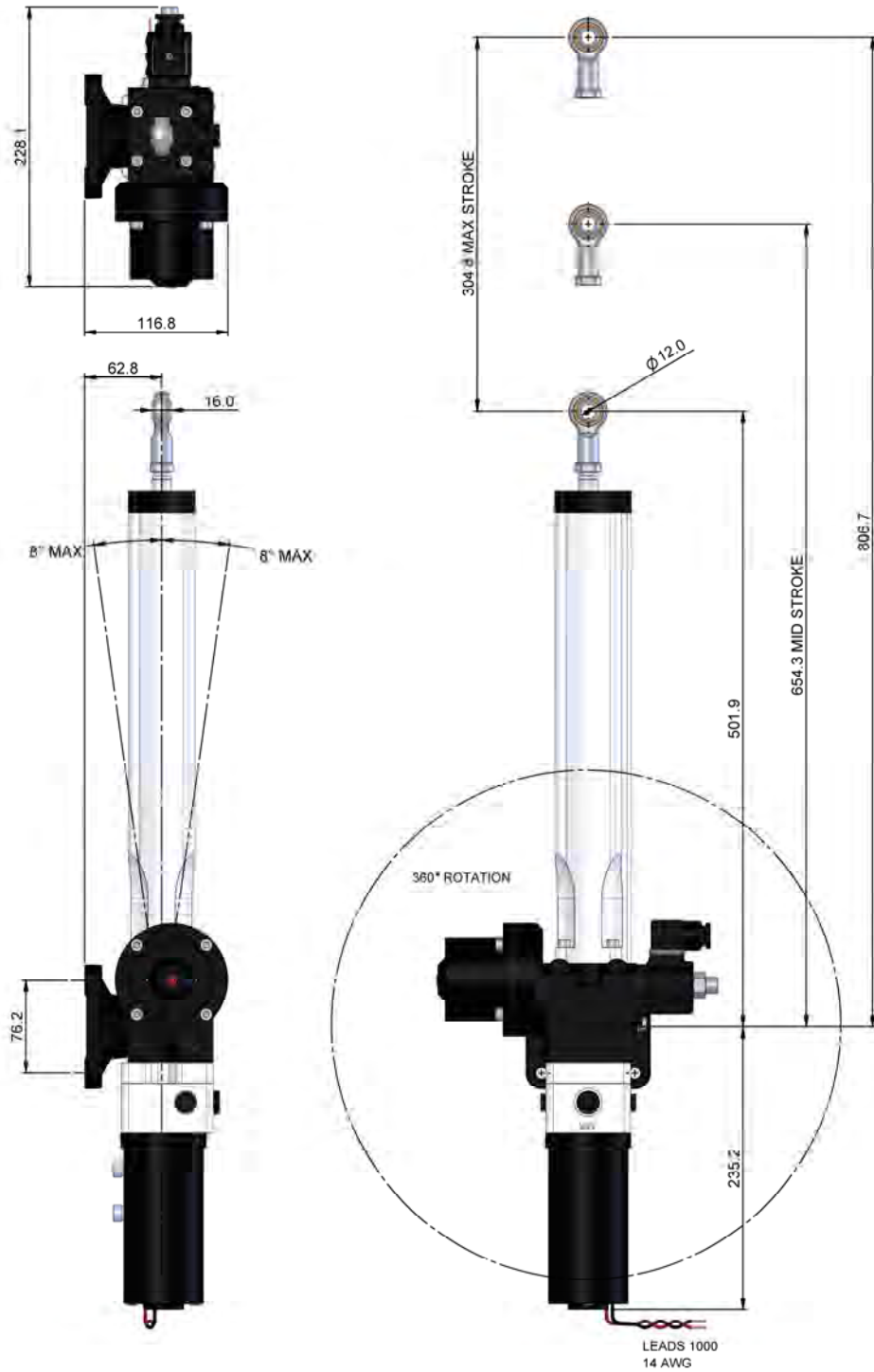

Quadrant

ML+40 L 10 (300mm stroke)

ML+40 L 20 (300mm stroke)

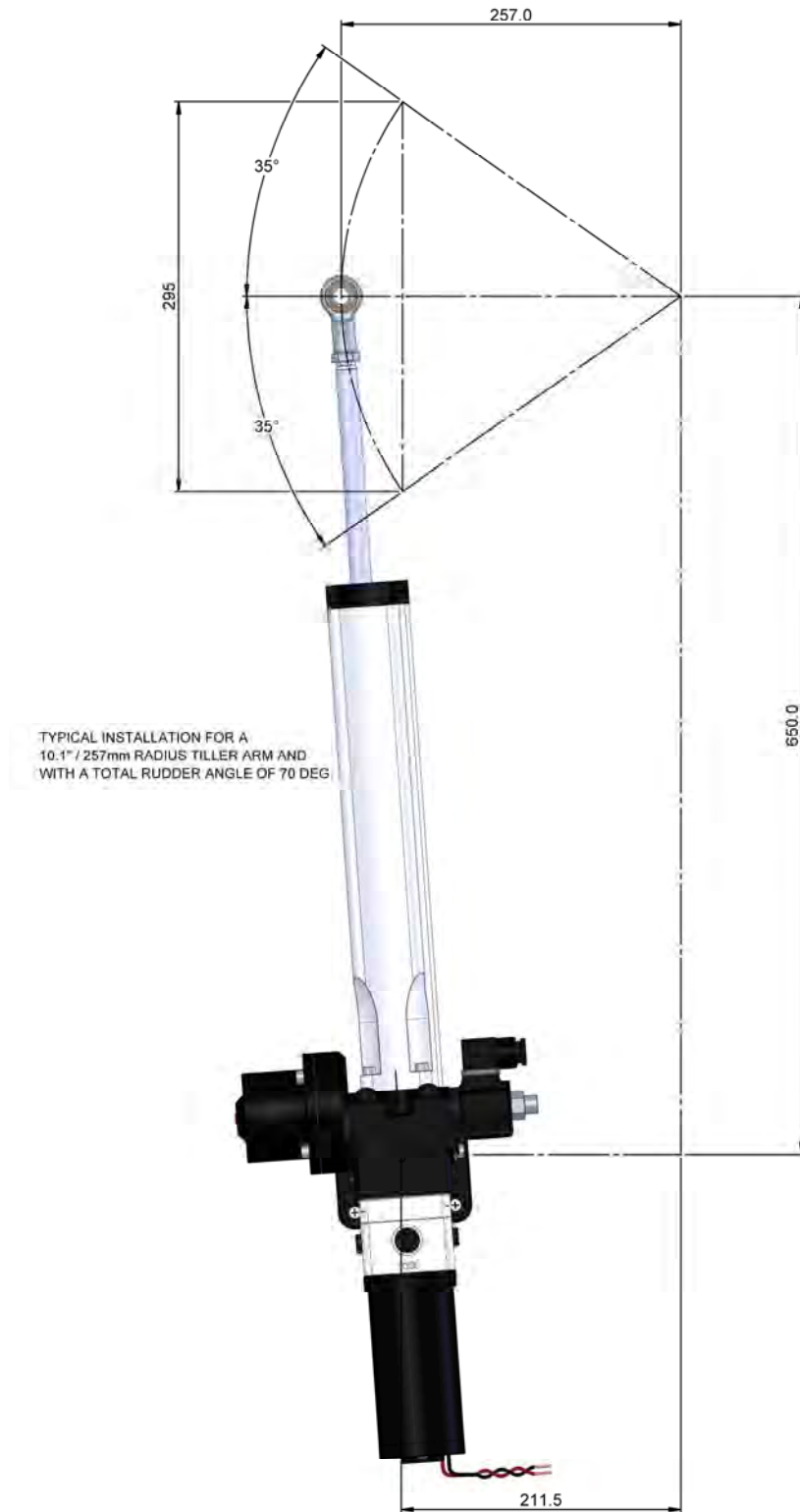

Performance Graph

Typical characteristics
Q8 Auto 15 oil @ 25°C

200mm stroke

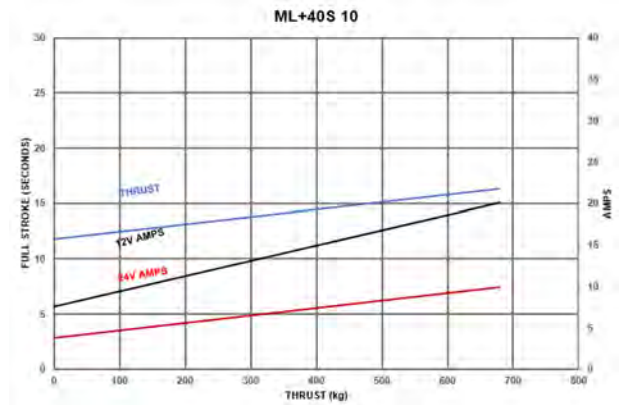
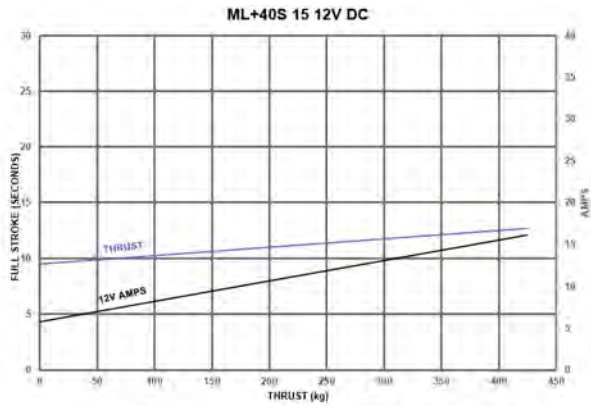

250mm stroke

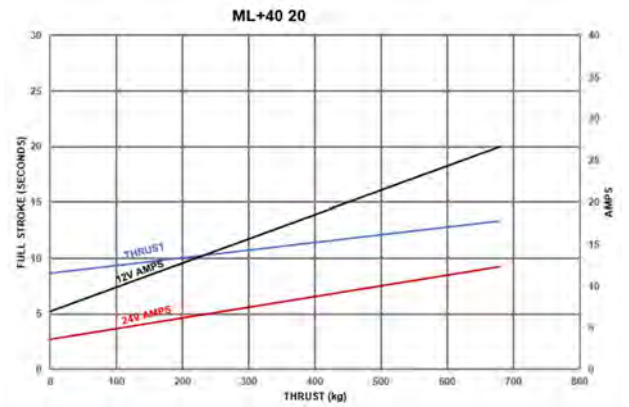
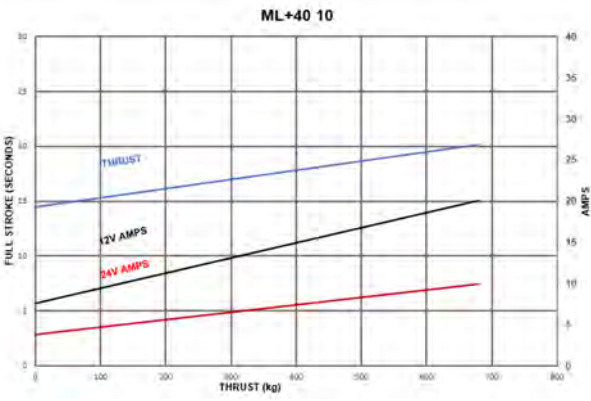

300mm stroke

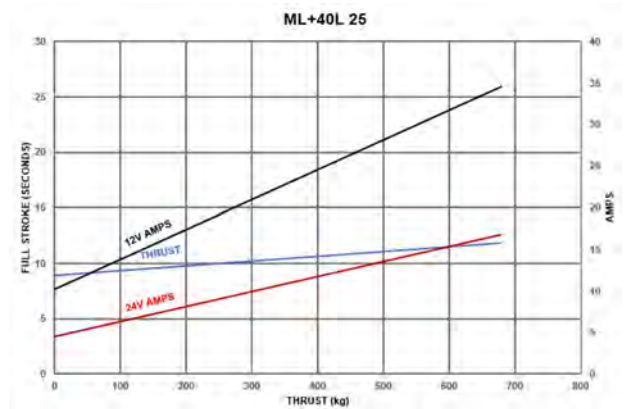
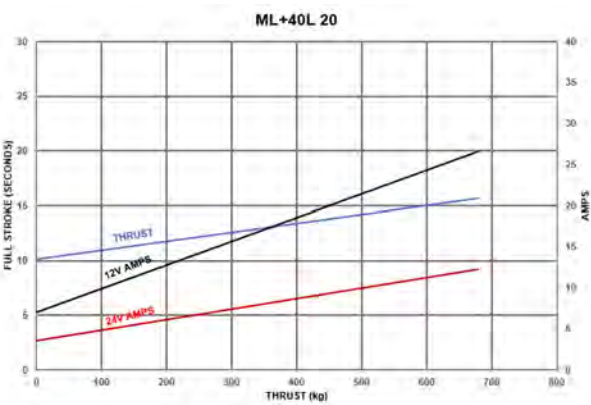

RUDDER POSITION SENSOR

The Hy-ProDrive integrated position sensor, designed and manufactured in house is compatible with our latest version of our ML+40 and HS+40 marine linear actuators.

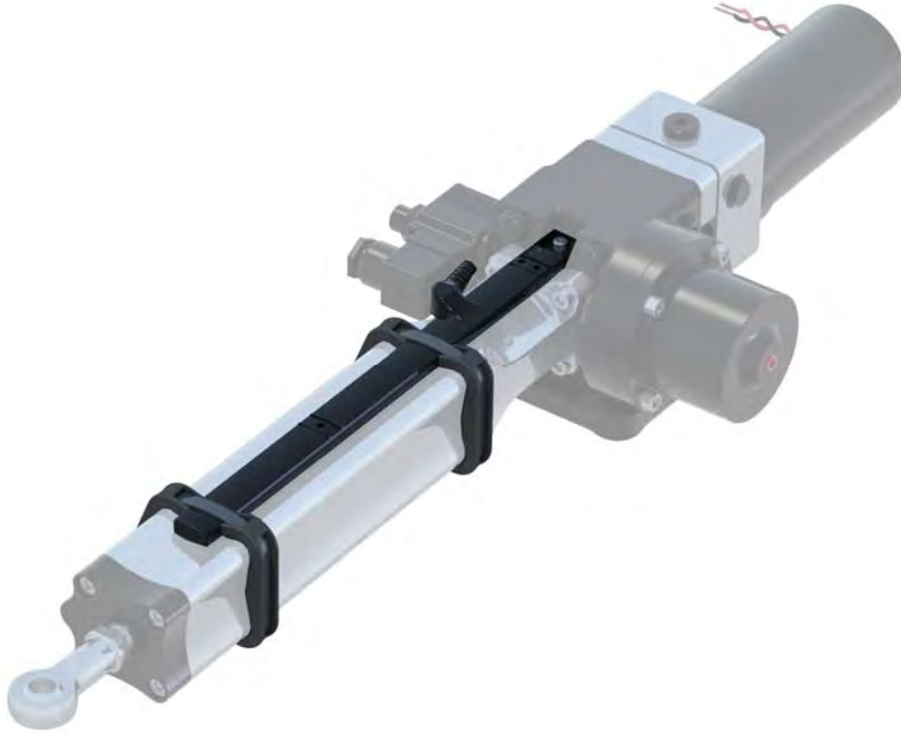

Description

Non-contact absolute position sensor.
The unit monitors the movement of the hydraulic piston, inside the steering cylinder.

Application

Mounted on an ML+40 or HS+40 marine autopilot drive, to provide rudder position data to the course computer.

Features

No moving parts or linkages for robustness and longevity.
Attaches directly to the cylinder with dedicated clips.
Can be fitted in the factory or retrofitted by the installer.
IP67 ingress protection
3 core cable length 1m.

Order Code

R4660-a

Technical Data

Supply voltage	3-15V DC
Typical	5V DC
Supply current	20ma
Output resistance	1.2 K Ω
Power up time	300 ms
RMS deviation from linear	0.3mm
Compass safe distance	BS EN 60945:2002 11.2
Steering Compass	1.0m
Standard Compass	1.5m
Mass	80g
Ingress protection	IP67
EMC protection	BS EN 60945:2002 (DC)
Ignition protection:	BS EN ISO 8846:2017
Wiring colours	
Gnd.	Black
V supply	Red
Output	Yellow

Full data sheet available on request

HS+40 ELECTRO-HYDRAULIC SECONDARY STEERING SYSTEM

The HS+40 hydraulic steering systems are designed specifically for marine secondary steering applications. They combine a hydraulic cylinder with clutch, reversing pump and reservoir in a compact installation. The solenoid clutch disengages the hydraulic circuit allowing manual mechanical steering to be used in conjunction with the hydraulic system.



Description

A pre-filled hydraulic system comprising a cylinder with clutch, pump and reservoir. The cylinder is free to float until the solenoid clutch is engaged, the reversing pump is then used to extend and retract it. Integral relief valves protect the installation from damage.

Application

Designed specifically for the marine autopilot market where they can be used on sailboats and power-craft with displacement and fast planing hulls. The pumps and cylinders can be matched to give the hard-over times and thrusts to suit the application. Further combinations using our 5 reversing pump sizes are also possible. Please refer to our data sheet PR-d for details of the reversing pump range.

Features

- Shorter than conventional cylinders.
- Integral solenoid bypass valve and relief valves.
- Fully serviceable.
- Quiet operation.
- A number of pump sizes with 12V/24V DC options.
- Marine environment protected (under-deck).
- Low power consumption.
- Fitting kit included.
- Low back-drive.
- Quick release mounting.
- Low profile.

Technical Data

Voltage	12V/24V DC			
Current	Typical Amp-hour		Typical current	
	60kg at 25% duty		intermittent 650kg	
	12V	24V	12V	24V
HS+4010	2.0A	1.0A	19.0A	9.0A
HS+4020	2.5A	1.3A	25.0A	12.0A
Full stroke time	12/24V DC (No load)			
	HS+4010	13 seconds		
	HS+4020	9 seconds		
Ingress protection	IP67			
EMC protection	BS EN 60945:2002 (DC)			
Ignition protection	BS EN ISO 8846:2017			
Ambient operating temperature	-15 to + 55 deg C			
Max thrust	703kg (Intermittent)			
Relief valve setting	62 bar (795kg)			
Orientation	Red lead to positive - Extends Black lead to positive - Retracts			
Clutch coil	12W			
Clutch connection	DIN 43650 (4-9mm lead) IP67			
Fluid	ISO VG10 to VG40 hydraulic mineral fluid to ISO 6743-4 HV			
Weight	11kg			
Feedback Transducer	Available upon request			

Rudder Position Sensor

An integral rudder position sensor can be specified for the HS+40 range.

The sensor has no moving parts and is fitted directly to the cylinder, detecting the pistons position.

The standard output signal is 0 to +5V, compatible with most autopilots.

Sensor Order Code See page 31

R4660-a

Installation Dimensions

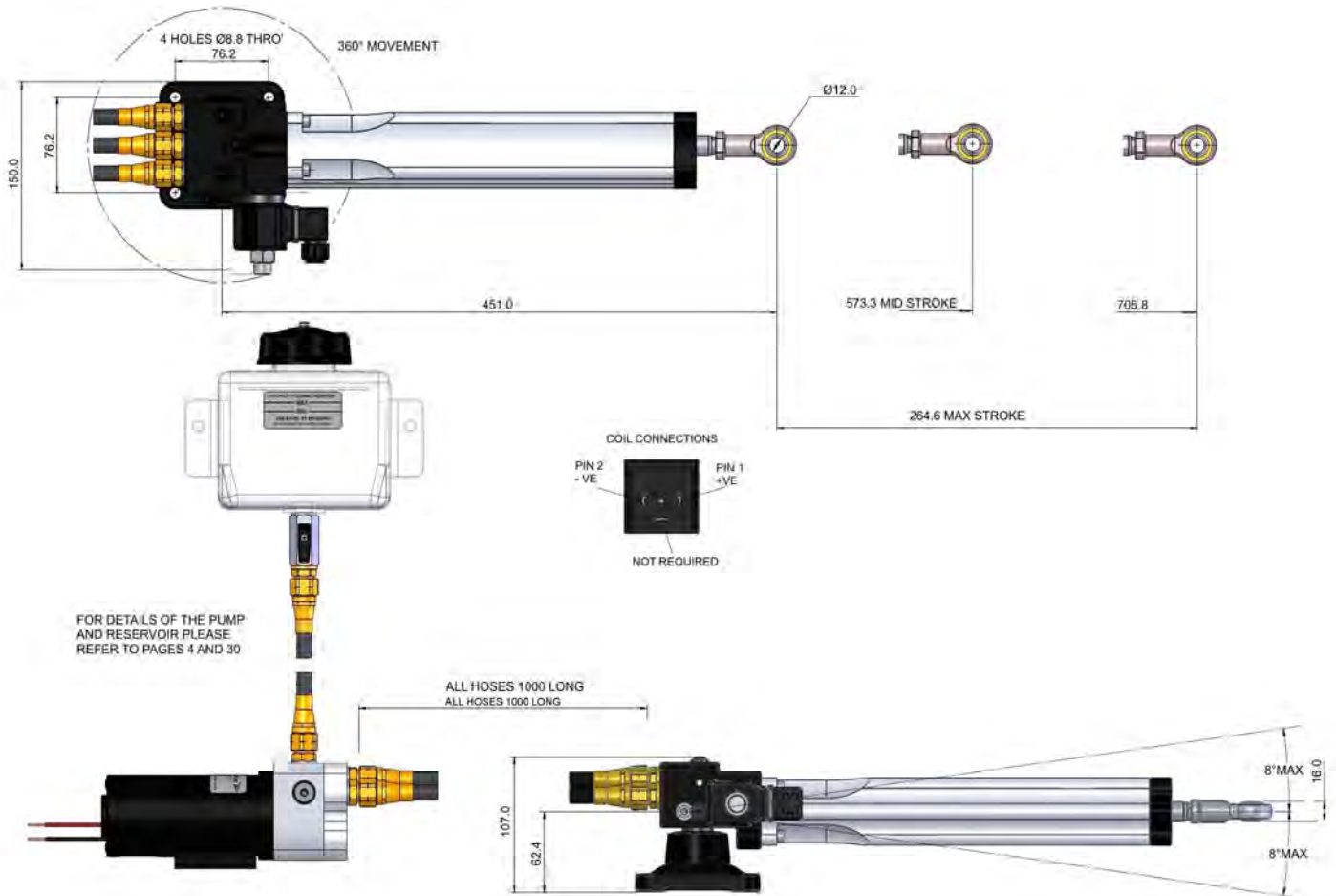

Performance Graphs

Typical Performance ISO VG10@ 25°C

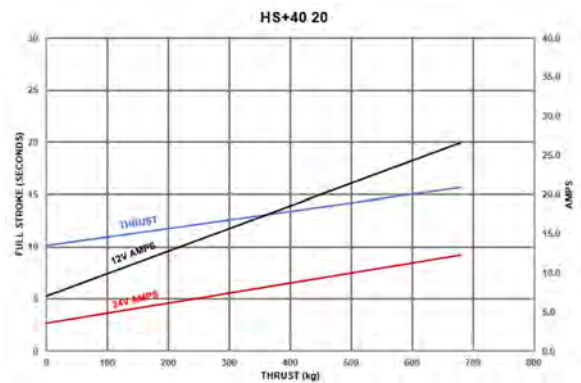
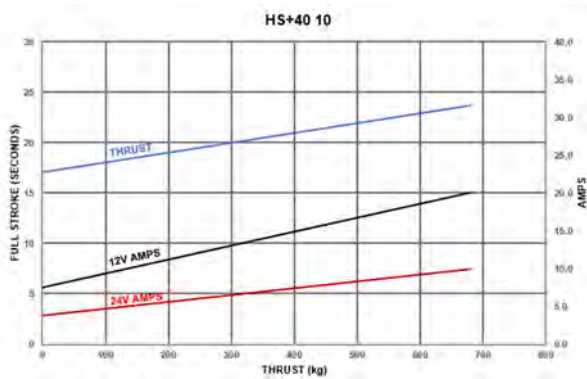

Order Code

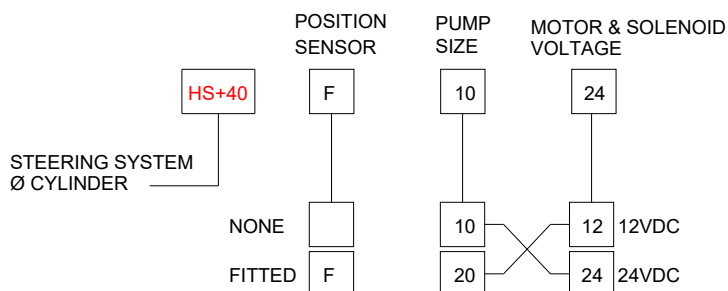

OTHER SPEED OPTIONS ARE AVAILABLE
PLEASE CONTACT US FOR DETAILS

Circuit Diagram

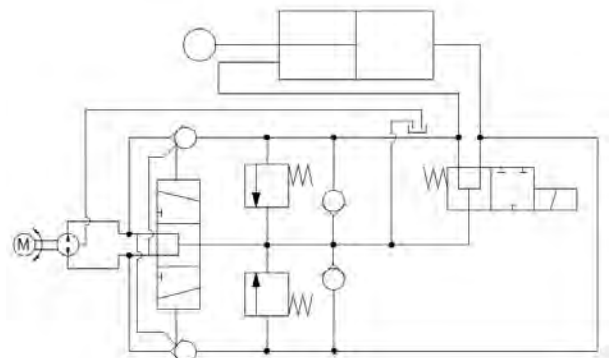

HS+50 ELECTRO-HYDRAULIC SECONDARY STEERING SYSTEM

The HS+ hydraulic steering systems are designed specifically for marine secondary steering applications. They are available with either a 2.5 lpm reversing pump or a number of sizes of PC pump. The systems are protected from rudder strikes by integral relief valves. A solenoid clutch is also fitted so that manual mechanical steering can be used.



Description

The hydraulic steering systems comprise of a compact cylinder which includes the relief valves and solenoid clutch, a reversing or constant running pump, marine hoses, fittings and a reservoir. The system comes filled ready for installation. A choice of pump sizes can be selected with single or twin cylinders to give a range of hard-over times and thrusts.

Application

Designed specifically for the marine autopilot market, they can be used on sailboats and powercraft with displacement and fast planing hulls. The pumps and cylinders can be matched to give the hard-over times and thrusts to suit the application.

Features

- Pre-filled ready to fit.
- Installation kit included.
- Shorter than conventional cylinders.
- Quiet operation.
- Low maintenance.
- Low power consumption.
- Integral solenoid bypass valve.
- Integral relief valves.
- Marine environment protected (under deck)
- Fully serviceable.
- 12V/24V DC options.
- Reversing or Constant Running pump options.
- Adjustable or non adjustable rod-ends
- Twin opposed cylinder option.

Technical Data

Voltage 12V/24V DC

Current	Typical Amp-hour		Typical current	
	92kg at 25% duty		intermittent 1016kg	
	12V	24V	12V	24V

HS+50	2.7A	1.4A	34.0A	15.5A
HS+50S	2.7A	1.4A	34.0A	15.5A

Full stroke time 12V/24V DC (No load)

HS+50 25	13 seconds
----------	------------

Ingress protection	IP67
EMC protection	BS EN 60945:2002 (DC)
Ignition protection	BS EN ISO 8846:2017

Ambient operating Temperature	-15 to + 55 deg C
-------------------------------	-------------------

Max operating thrust	1080kg (Intermittent)
----------------------	-----------------------

Relief valve setting	62 bar (1080kg)
----------------------	-----------------

Orientation	Red lead to positive - Extends Black lead to positive - Retracts
-------------	---------------------------------------------------------------------

Clutch coil	12W
-------------	-----

Clutch connection	DIN 43650 (4-9 mm cable) IP67
-------------------	-------------------------------

Fluid	ISO VG10 to VG40 hydraulic mineral fluid to ISO 6743-4 HV
-------	-----------------------------------------------------------

Weight	14 kg
--------	-------

Feedback Transducer	
---------------------	--

Ingress Protection	IP66
Lead	1.0m
Resistance	13.0kΩ

Performance Graph

Typical Performance

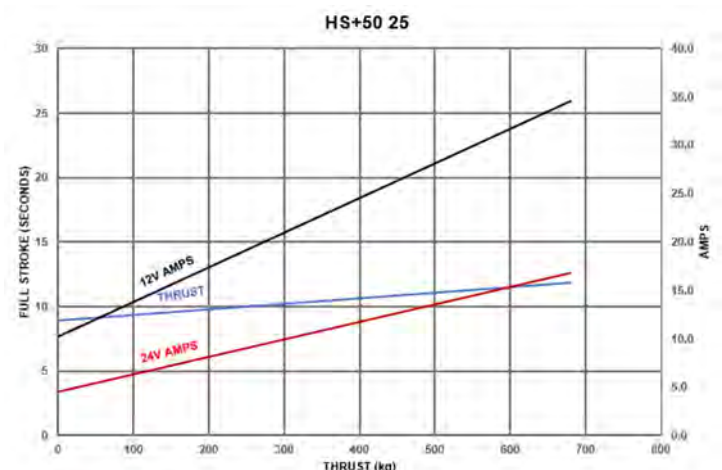

Installation Details

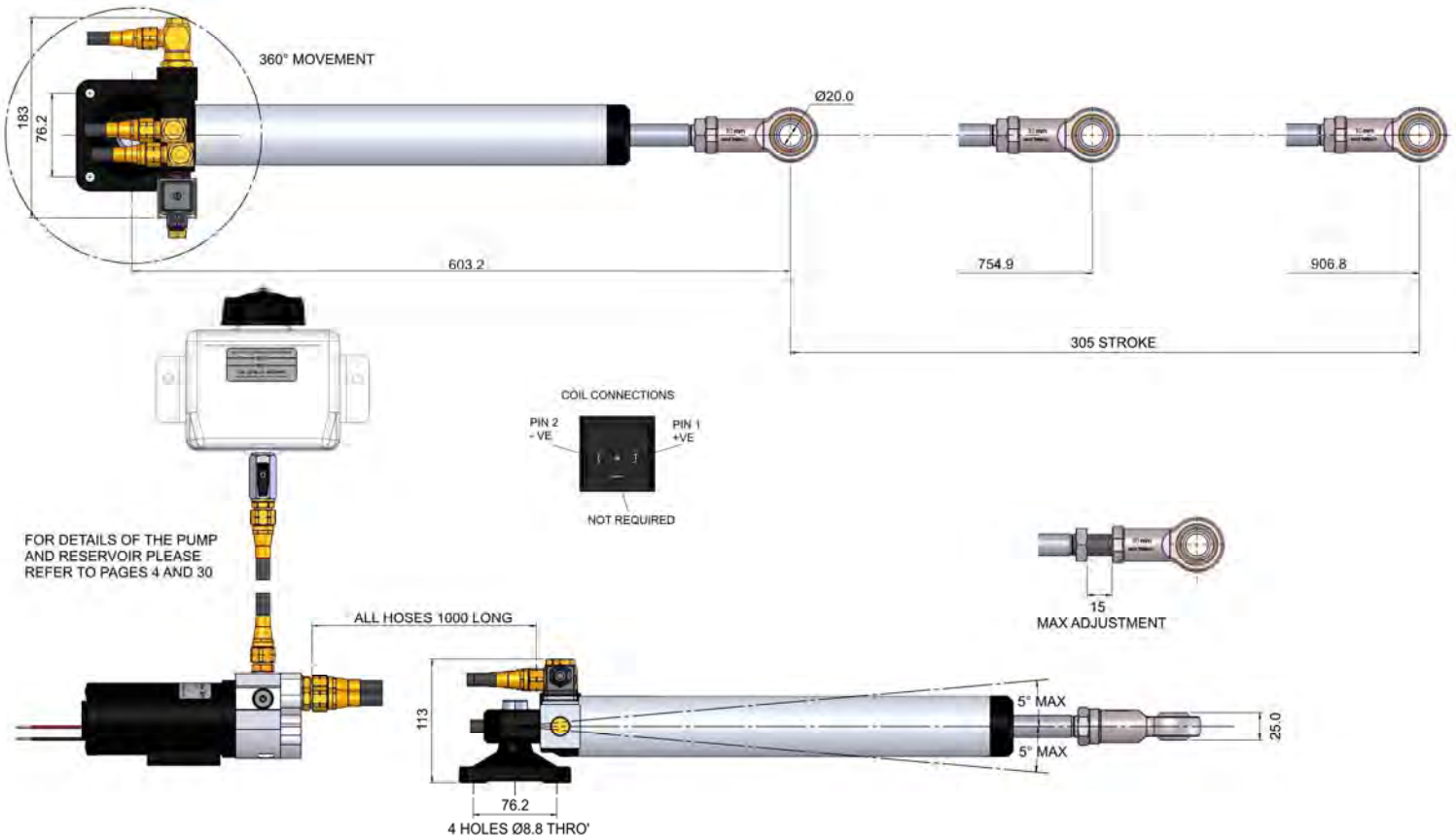

Rudder Feedback Sensor

An integral rudder position sensor can be specified for the HS+50 range.

The sensor has no moving parts and is fitted directly to the cylinder, detecting the pistons position.

The standard output signal is 0 to +5V, compatible with most autopilots.

Sensor Order Code

HS+50F



Circuit Diagram

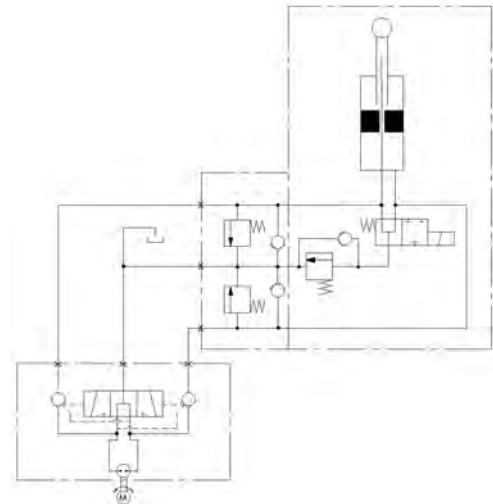

Order Code

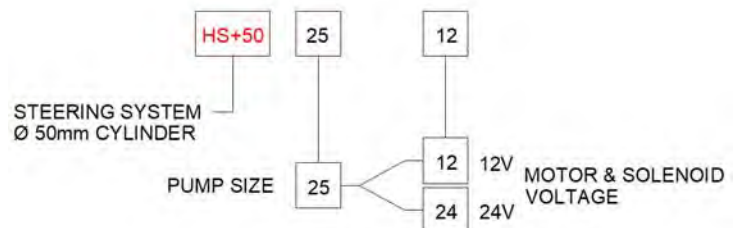

OTHER SPEED OPTIONS ARE AVAILABLE
- PLEASE CONTACT US FOR DETAILS

HS+50 PC45 ELECTRO-HYDRAULIC SECONDARY STEERING TWIN SYSTEM

Designed for larger vessels the HS+50 PC45 S comprises 2x HS+50 steering cylinders and the PC45 constant running pump. It comes complete with all hoses, fittings necessary to install and operate the system. It comes in kit form ready for assembly.



Description

Comprising 2 steering cylinders with integral unloading valves, a 4.5 l/min constant running pump with directional solenoids, separate reservoir, and a set of 1000mm hoses + fittings. The cylinders are supplied with a fitting kit, which includes a tiller pin and quick release tab. The pump is supplied with a starter relay, to enable the auto pilot to start the motor remotely. Steering is achieved by switching the solenoid operated valve.

Application

Designed specifically for the marine autopilot market and intended for commercial sailboats and power-craft with mechanical steering. The steering can be unloaded to enable the craft to be steered manually.

Features

- Installation Kit included.
- 12V/24V DC options
- Compact twin opposed cylinders.
- Integral unloading valves.
- Manual override on steering solenoids.
- Remote reservoir.
- Compatible with many autopilots.
- Optional Feedback transducer

Technical Data

Voltage	12V/24V DC	
Current	Typical Amp hour	Typical Current (intermittent) 2125Kg
	250 Kg 25% duty	12V 24V
	10.5Ah 7.5Ah	30.0A 22.5A
Full stroke (No load)	14.7 seconds	
Ingress protection		
Cylinder	IP67	
Motor	IP44	
EMC Protection	BS EN 60945:2002 (DC)	
Ambient operating Temperature	-15 to + 55 deg C	
Max operating thrust	2125Kg (Intermittent)	
Relief valve setting		
Cylinder	62 bar	
Pump	58 Bar	
Clutch coils	12W x2	
Clutch connection	DIN 43650 (4-9 mm cable) IP67	
Fluid	ISO VG10 to VG40 hydraulic mineral fluid to ISO 6743-4 HV	
Capacity	6 L	
System Weight	28 kg	

Installation Dimensions

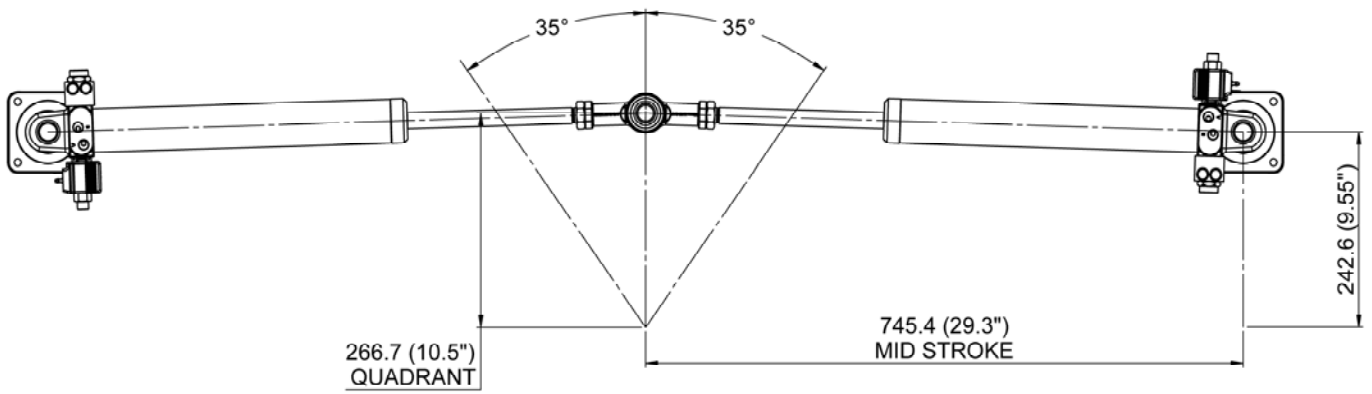

Circuit Diagram

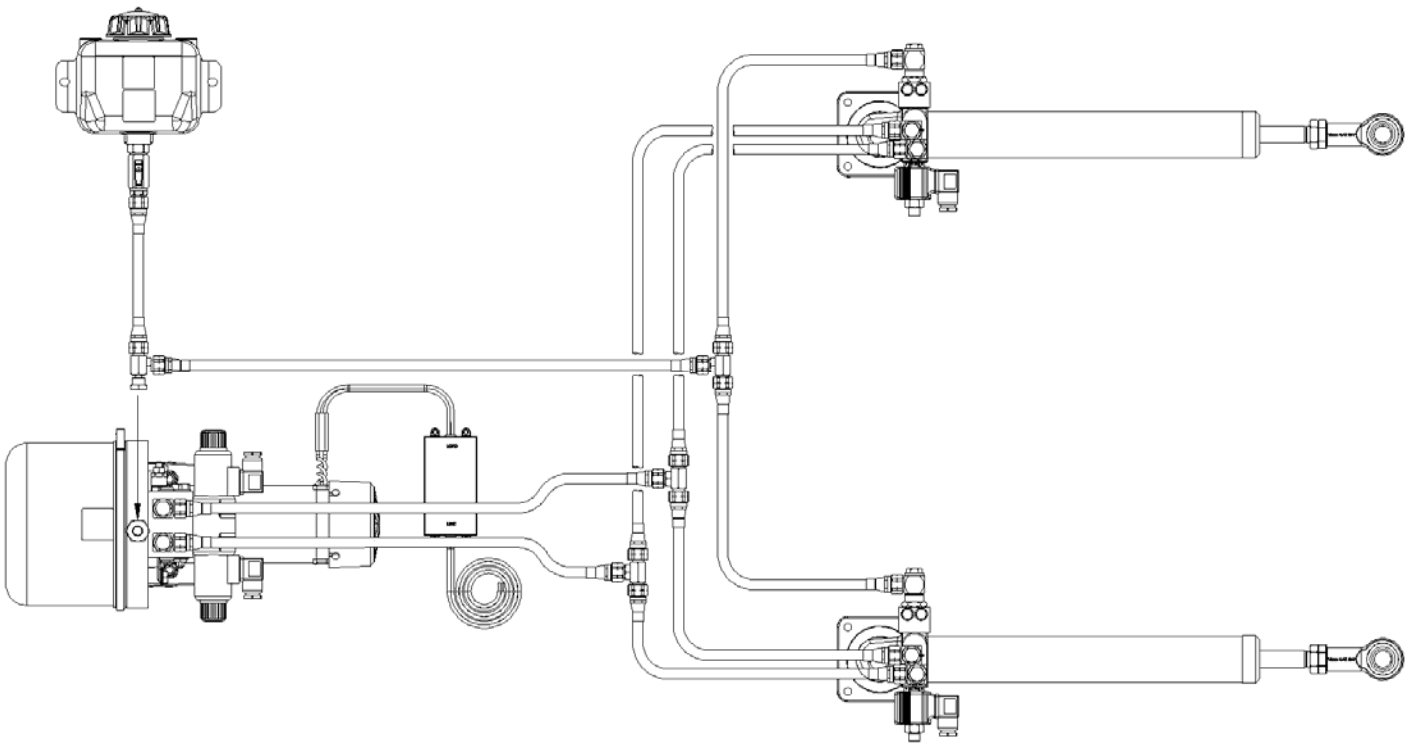

Performance Graph

Typical Performance
ISO VG10 @ 25°C

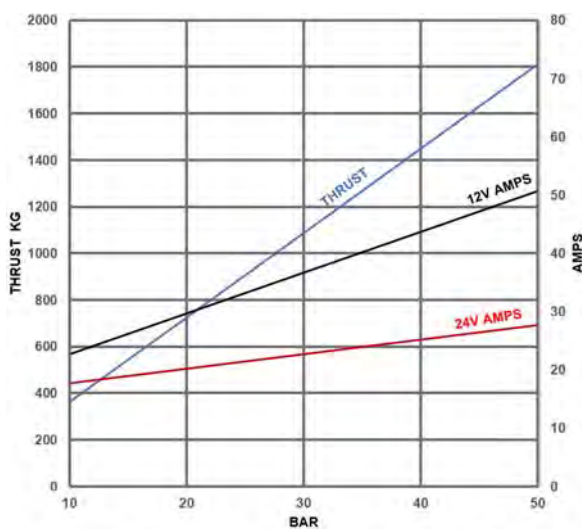

Order Code

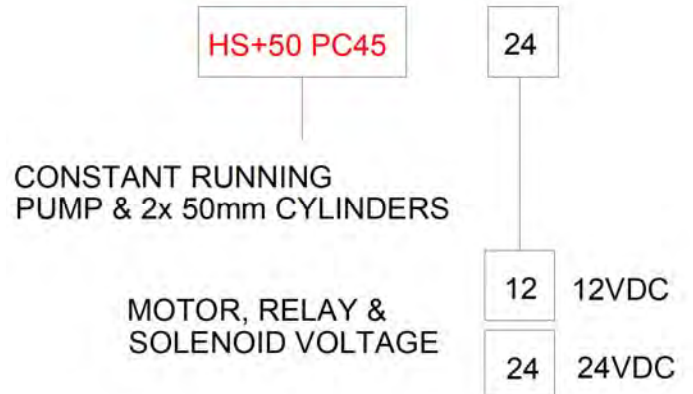

MARINE AUTOPILOT PILOT OPERATED CHECK VALVE

The marine autopilot pilot operated check valve is a line mounted valve that is used to lock steering cylinders. The G1/4 valve can also be used when a helm pump is without check valves or to prevent the autopilot pump back driving the helm wheel.

Description

This G1/4 (BSPP) in-line check valve is designed to close the 'C' ports until a pilot pressure is applied to the 'P' ports in order to move the check valve piston and so open the port. The body is made from anodized aluminium for protection against the harsh marine environment whilst the internal components are made from hardened and toughened steel for extended life.

Application

Designed to be used to positively lock steering cylinders or to prevent the back drive of the helm steering wheel by the autopilot pump should the helm pump not have check valves.

It is designed for use with both balanced and unbalanced cylinders. Where an unbalanced cylinder is used the additional 'R' port is connected to the helm pump reservoir bottom port.

Features

- Positive locking of the cylinder.
- Hardened check piston.
- Toughened check seats.
- High grade chromium balls.
- Suitable for balanced and unbalanced cylinders.
- Mounting holes.
- Port identification.
- Anodised aluminium



Technical Data

Rated flow	4.5 l/min
Maximum pressure	72 bar
Pilot ratio	2.25:1
Port size	G1/4 (BSPP)
Ambient operating Temperature	-15 to + 55 deg C
Fluid	ISO VG10 to VG40 hydraulic mineral fluid to ISO 6743-4 HV
Weight	0.31 kgs

Order Code

R2254

Circuit Diagram

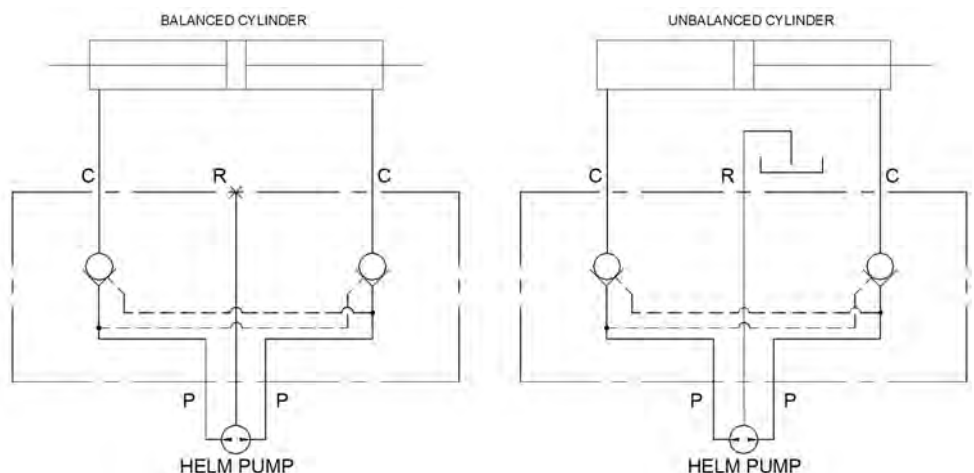

Installation Details

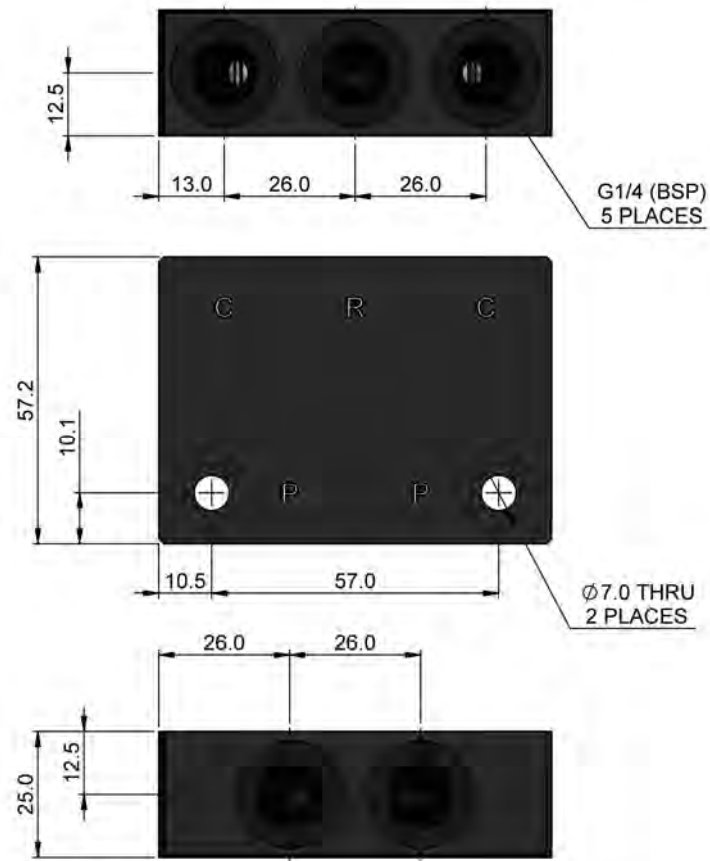

Installation Diagram

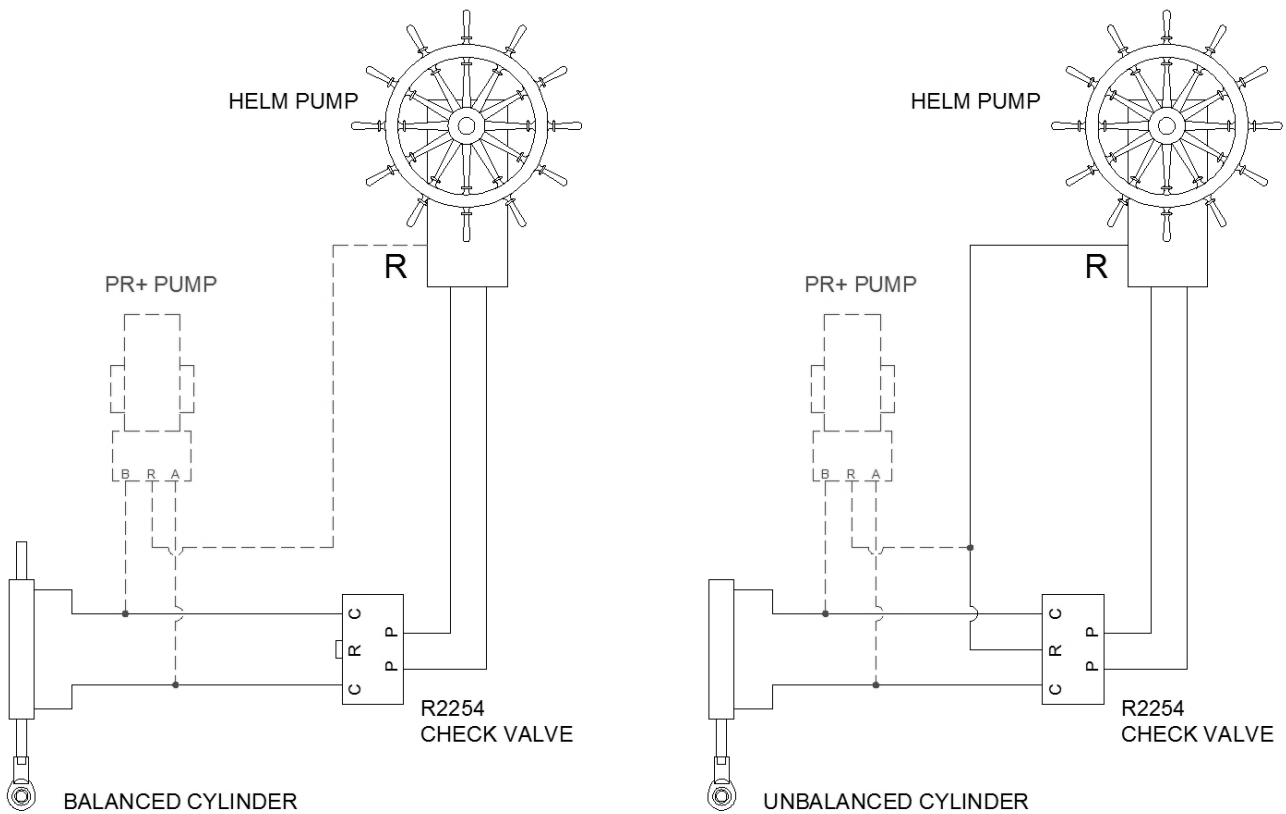

MARINE AUTOPILOT SECONDARY STEERING CYLINDER UNLOADER VALVE

The Autopilot Cylinder Unloader valve is a line mounted valve, used to bypass the hydraulic steering cylinder to enable the boat to be steered manually. The solenoid operated valve is connected to the 'clutch' connection of an autopilot. It is available in 12/24 V DC and can be used in systems up to 72 bar. It can be used with balanced and unbalanced cylinders.

Description

The normally open solenoid operated unloader valve is a compact line mounted G1/4 (BSPP) ported manifold. The low power consumption 12W coils are available in 12V/24V DC variants. With an anodized body and an IP67 rating this valve has been designed for the harsh marine environment.

Application

Designed to be used in autopilot steering applications, this valve is used to bypass the autopilot hydraulic steering cylinder so that manual steering can be used. It can be used with balanced cylinders or by connecting the 'R' port to the reservoir with unbalanced cylinders. The design has been optimized to enable the coil to be energized for extended periods of time.

Features

- Marine environment protected
- Compact .
- 12V/24V DC variants.
- Low power consumption.
- Used for balanced/unbalanced cylinders.
- Line mounted.
- Long energizing capacity.

Performance Graphs

Typical performance
ATF (40 cSt @40°C) @ 25°C

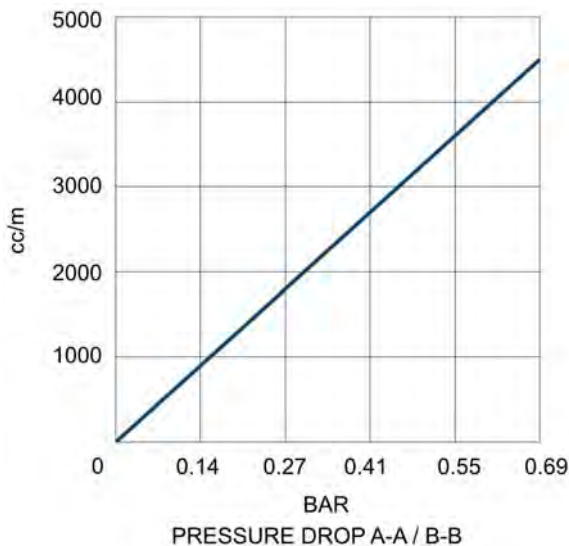

Technical Data

Voltage	12V/24V DC
Power	12W
Rated Flow	4.5 l/min
Maximum pressure	72 bar
Ambient operating temperature	-15 to + 55 deg C
Protection	IP67
Cable Ø (not supplied)	4-9mm
Fluid	ISO VG10 to VG40 hydraulic mineral fluid to ISO 6743-4 HV
Weight	0.66 kg

Order Code

R2345-O	12	
	12	12V
	24	24V

SOLENOID VOLTAGE

Installation Details

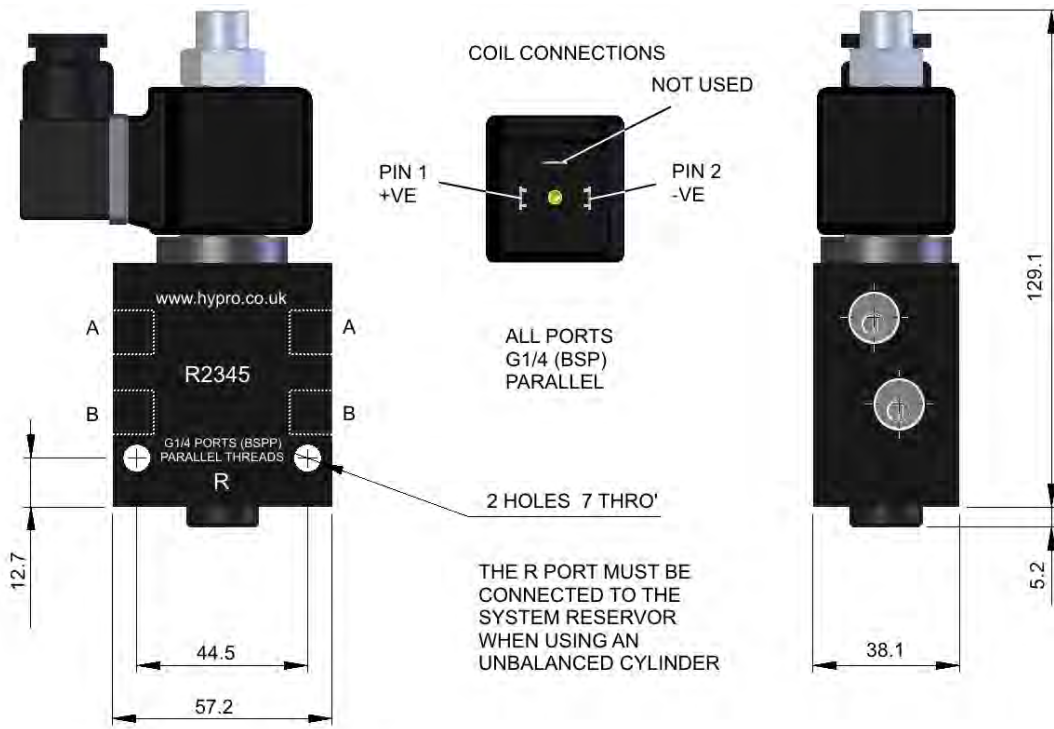

Installation Diagram

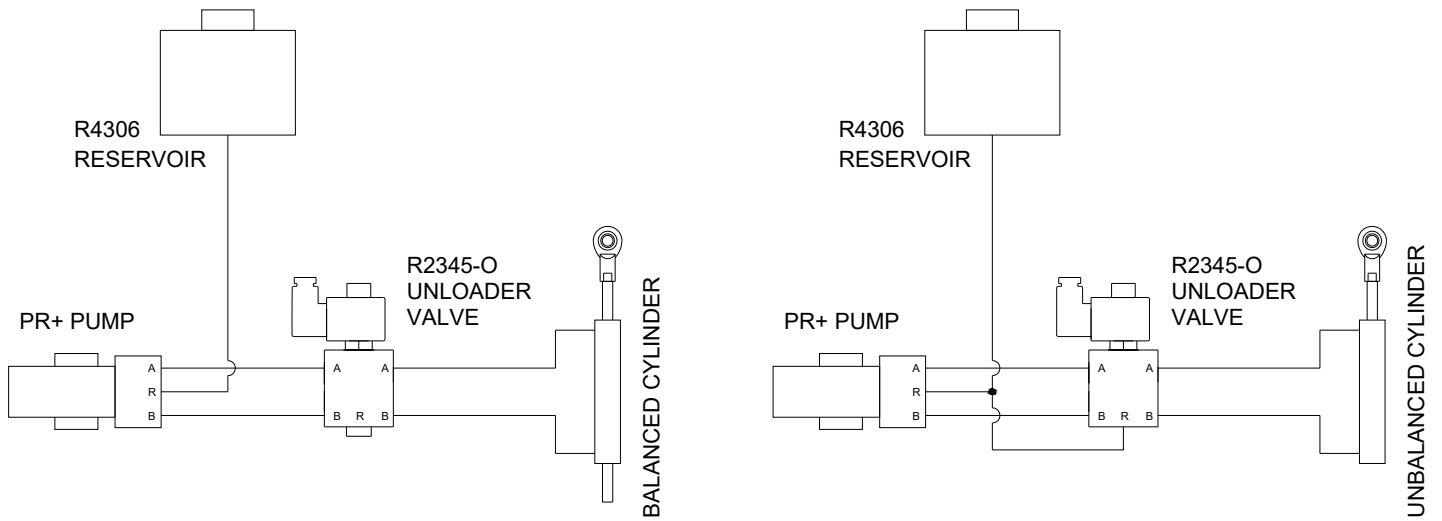

Circuit Diagram

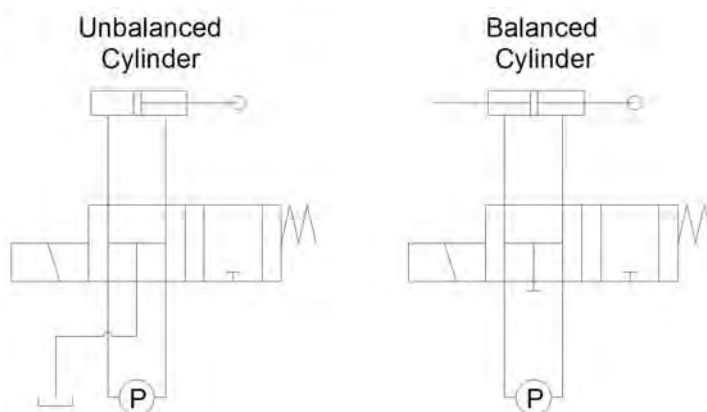

R4306 HYDRAULIC STEERING FLUID RESERVOIR

Specifically developed for hydraulic steering systems this robust reservoir comes complete with marine grade isolator tap, tethered filler / breather cap and a pick up that allows extreme heel angles without spillage or air ingress into the system. Manufactured from high-density translucent polyethylene for 'at a glance' checking of fluid level.

Technical Data

Capacity

Maximum 0.94 Litre
 Recommended 0.70 Litre
 (ref. 70° heel angle)

Performance

Temp min -20°C
 Temp max +55°C

Materials

Body HDPE
 Tap Chrome plated brass
 Fittings Brass
 Seals Nitrile
 Weight empty 0.48kg
 Connection 5/8 SAE male 45° flare
 (G1/4 BSPP male option available
 reference 4306 A02)

Compatible

Fluids Mineral based hydraulic

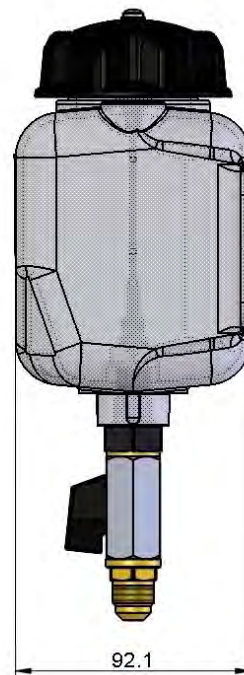
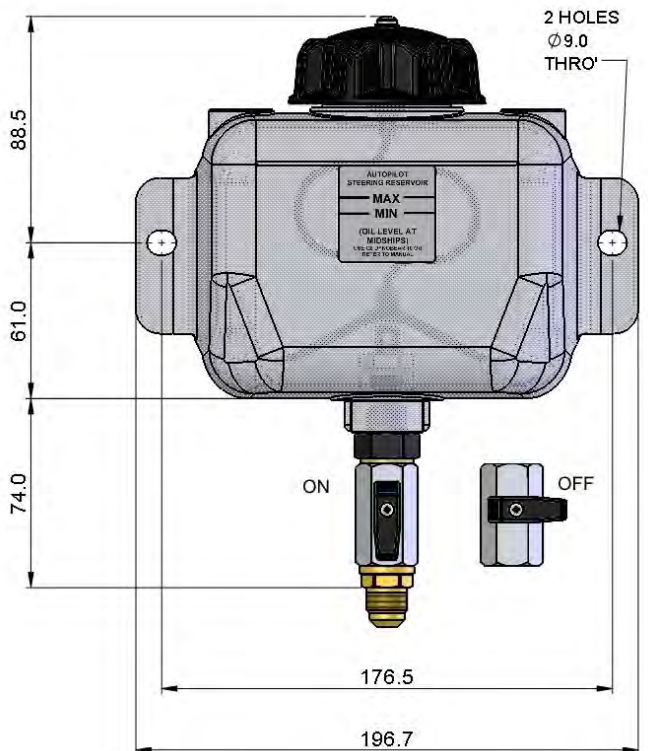

Order Code

R4306

R4306 -A02

STEERING
 FLUID
 RESERVOIR

STANDARD

G1/4 (BSP)

FITTING

R4306

A02

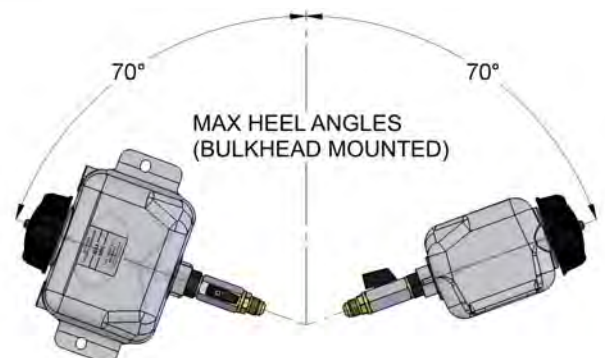

SPARES AND ACCESSORIES

Marine Steering Fluid

HyProDrive Marine Steering Fluid contains special additives which reduces friction by more than 25% when compared to conventional oils. The additive eliminates stick slip and judder that sometimes occurs in hydraulic systems. Gives outstanding low wear performance. Use in all of our marine products. Supplied in 1.0 Litre containers.



Order Code

MSF VG10

Marine Steering Hoses

Specialised marine hose assemblies which feature low volumetric expansion for fast response and advanced polymer materials for flexibility with long-life in corrosive marine conditions. The end fittings are all brass construction with 5/8 SAE female 45° flare threads. Available in any length.



Order Code

016615

1.0

Length (metres)

Solenoid Unloader Cartridges

NO (normally open) solenoid cartridges complete with either 12V/24V DC 12W coil. To suit all HyPro Drive Linear Actuators, Steering systems and Unloader Valves.

They are also direct replacements for the older R3760, R3880 and R4048 cartridges (square coils).



Order Code

R4112-aO

12

VOLTAGE

12

24

Legacy Motor Brushes

Spare motor brushes to suit our older models of pumps, actuators and systems are available. Please see our website for details:

www.hypro.co.uk



Useful Data

Cylinder Volume

Cylinder Area x Stroke - Rod Area x Stroke

HO to HO (secs)

$\frac{\text{Cylinder volume (cc)} \times 60}{\text{Pump flow (cc)}}$

Pressure

1 bar = 14.5 psi

Cubic inches to Cubic centimeters

$\text{in}^3 \times 16.4 = \text{cm}^3$

Cubic centimeters to Cubic inches

$\text{cm}^3 \times 0.061 = \text{in}^3$

SPARES AND ACCESSORIES

ML+40 & HS+40 Fitting kit

Replacement tiller bolt (12mm) and fitting kits for ML+40 & HS+40.

Includes, bolts, nuts and washer for base assembly.



Order Code

R4055-a

HS+50 Fitting kit

Replacement tiller bolt (20mm) and fitting kits for HS+50.

Includes, bolts, nuts and washer for base assembly.



Order Code

R3790-a

Seal kits

PR+ Reversing pump

Order Code

PR+ sk

ML+40 Actuator

ML+40-sk

HS+40 Steering system

HS+40-sk

HS+50 Steering system

HS+50-sk





We also manufacture a range of mobile Hydraulic Control Valves

These are used in fishing , transport, agriculture, industrial, mining, construction industries.

The range covers:

40 to 100Lpm
 250bar
 Mobile spool valves
 Manual & Solenoid operation
 Internal oil pilot—Ideal for harsh environments

Call or Email our friendly Sales Team for further details:

Tel: +44 (0) 1626 863634

Email: sales@hypro.co.uk Or visit www.hypro.co.uk/products/hydraulic-control-valves/



About Hydraulic Projects

Our in-house design and technical teams offer the expertise and support expected of an established world-class manufacturer. Our customers, ranging from the agricultural, transport, rail, fishing, construction and industrial sectors, expect named personal support, excellent quality and a rapid service with full back-up...
....we aim to deliver in full.

Call us today to discuss a bespoke solution from our extensive range or simply for competitively priced spares.

Full technical details of our entire range are available to download from our website

www.hypro.co.uk



Contact details:

Hydraulic Projects Limited
Dawlish Business Park
Dawlish
Devon
EX7 0NH
U.K

Tel: +44(0)1626 863634

Fax: +44(0)1626 866283

email: sales@hypro.co.uk
website: www.hypro.co.uk

ISO 9001:2008



Certificate No. 11935