

Universal radio receiver

Product reference : 90-60-250



INSTALLATION GUIDE

Zi de Kerandré – Rue Gutemberg – 56700 – HENNEBONT – FRANCE

www.nke-marine-electronics.com



+33 297 365 685

nke

MARINE ELECTRONICS

TABLE OF CONTENTS

1	PRESENTATION	3
2	“MAN OVER BOARD” SAFETY FUNCTION	4
2.1	GYROPILOT BEHAVIOUR.....	4
2.2	SUSPENDING AND DISABLING THE “MAN OVER BOARD” ALARM,.....	5
3	RECEIVER AND OFFSET ANTENNA INSTALLATION	5
3.1	PACKING LIST FOR THE RECEIVER 90-60-250.....	5
3.2	LIST OF ACCESSORIES.....	5
3.3	SPECIFIC PRECAUTIONS FOR THE INSTALLATION OF THE RADIO SYSTEM	5
3.4	SPECIFIC PRECAUTIONS FOR SHIPS MADE WITH METAL AND CARBON	7
3.5	POSITION AND INSTALLATION OF THE RADIO RECEIVER HOUSING	8
3.6	CHECKING THE RADIO TRANSMISSION FROM THE TRANSMITTERS TO THE RADIO RECEIVER	8
4	CONNECTION TO THE TOPLINE BUS AND TO THE NMEA BUS.....	9
4.1	CONNECTION OF EXTERNAL RELAYS	10
5	RECEIVER INITIALIZATION AND PAIRING OF THE TRANSMITTERS	11
5.1	DESCRIPTION OF THE RADIO RECEIVER	11
5.2	ABOUT THE PAIRING.....	12
5.3	INITIALIZATION OF THE RADIO RECEIVER.....	12
5.4	PAIRING THE <i>GYROPILOT</i> TRANSMITTER WITH THE <i>RADIO RECEIVER</i>	12
5.5	PAIRING THE <i>MULTIFUNCTION</i> TRANSMITTER WITH THE <i>RADIO RECEIVER</i>	13
5.6	PAIRING THE <i>CREW</i> TRANSMITTER WITH THE <i>RADIO RECEIVER</i>	13
5.7	SET AN ADDRESS TO THE RADIO RECEIVER	13
6	DIAGNOSTIC FOR 1ST LEVEL TROUBLESHOOTING.....	14
7	TECHNICAL SPECIFICATIONS.....	155

1 PRESENTATION

The **universal radio receiver** is an interface allowing the communication between **TOPLINE transmitters** and the **Gyropilot** or the **Multifunction** displays.

Three types of **TOPLINE transmitters** communicate with the **universal radio receiver** :

- The **Gyropilot transmitter**.
- The **Multifunction** display transmitter.
- The **crew** transmitter.

The **radio receiver** is connected to the **TOPLINE** bus of your installation. It is designed to communicate with **8** transmitters.

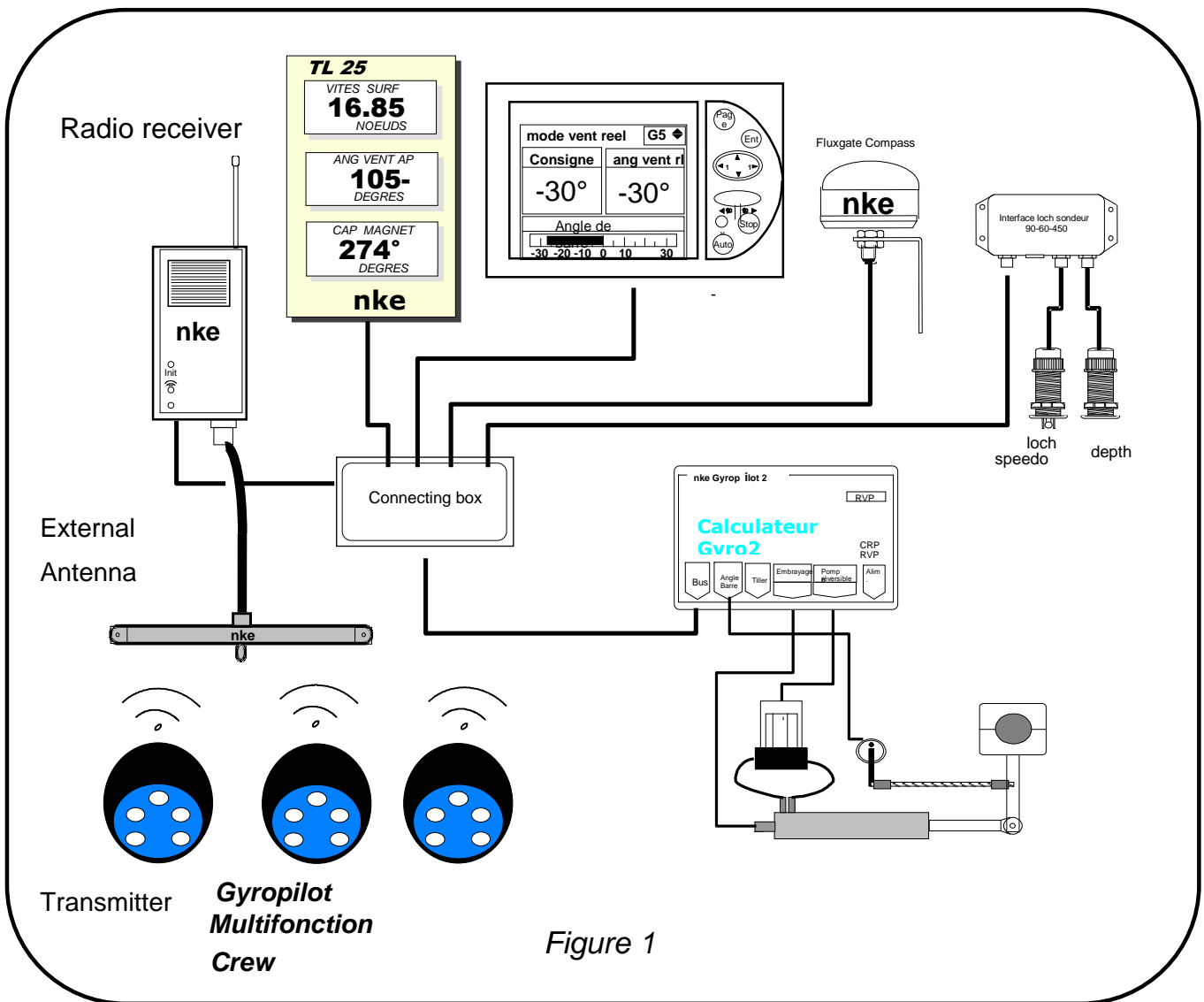

2 “MAN OVER BOARD” SAFETY FUNCTION

Each transmitter integrates a “**man over board**” safety function. When a person carrying a transmitter falls over board and the ship sails further than 50 metres away, the “**man over board**” alarm is triggered. The following functions are activated:

- **On display:** the estimated heading and distance to reach the man over board are displayed when a speedometer and a compass are connected to the **TOPLINE bus**. If your installation only comprises a speedometer, then only the estimated distance will be displayed.
- **The audible alarm:** the radio receiver sounds an audible alarm, until the “man over board” function is acknowledged (see chapter 2.1).
- **The NMEA output**

Two standard 0183 NMEA frames, relative to the “Man over board” function, are transmitted on the NMEA + output 3 times per second (see chapter 4):

MLR frame

```
$ P M L R , 0 5 , 0 1 , 0 2 , 0 3 3 7 * 0 2 <cr>< lf>
```

```
| | | Checksum
```

```
| | Data bytes (here 02 = MOB key on the GPS)
```

```
| Number of data bytes (01 = only 1 data byte)
```

```
Type of phrase (05 = simulating key pressing on the keyboard)
```

This frame launches an “MOB” procedure on compatible MLR GPS.

WayPoint Location

```
$ T R W P L , , , , M O B * 2 1 <cr>< lf>
```

```
|
```

```
WayPoint Name
```

Note that the parameters of these frames are constant. The radio receiver does not calculate any parameter in these phrases.

2.1 Gyropilot behaviour

- In **alone** mode:

the ship is equipped with a masthead unit and the gyropilot is set on “auto”: The **Gyropilot** automatically switches to **wind mode** and applies a “0°” set point, in order to position the ship into the wind.

The Gyropilot is set on “stop”: The **Gyropilot** automatically switches to “**auto**” and “**rudder mode**”, and positions the helm with a **+/- 40°** set point in relation to the previous position of the helm.

If the ship is not equipped with a masthead unit : the **Gyropilot** automatically switches to “**rudder mode**”, and positions the helm with a **+/- 40°** set point in relation to the previous position of the helm.

- In **crew** mode: the activation of the “**man over board**” function does not trigger any action on the **Gyropilot**.

(Reminder: The crew / alone mode selection can only be carried out with GPG V1.42 or above and calculator V2.30 from 21/07/03 or a later version.)

2.2 Suspending and disabling the “Man over board” alarm,

To suspend the audible alarm (during the recovery operation of the man over board, for example), press any key on your transmitter. The estimated heading and distance to reach the man over board remain on display.

To disable the “Man over board” alarm, you must cut off the power supply of your **TOPLINE** installation.

Note that if you do not cut off the power supply, the information on heading and distance to the “**man over board**” are saved to the memory, no matter what commands are performed on your **TOPLINE** installation.

3 RECEIVER AND OFFSET ANTENNA INSTALLATION

3.1 Packing list for the receiver 90-60-250

- One radio receiver equipped with 3 metres of cable.
- One mounting bracket.
- One outside receiving antenna equipped with 5 metres of cable.
- One guide.

3.2 List of accessories

- Outside antenna : 90-60-277
- **Gyropilot** transmitter : 90-60-247
- **Multifunction** transmitter : 90-60-248
- **Crew** transmitter : 90-60-251
- TOPLINE terminal box : 90-60-121 or 90-60-417 (with NMEA input).
- **TOPLINE bus** cable 20-61-001.

3.3 Specific precautions for the installation of the radio system

On the ship, the **nke** radio system comprises :

- One receiver equipped with a small antenna.
- One outside antenna.
- One or more **TOPLINE** radio transmitters.

The propagation of radio waves, emitted by the transmitters to the receiver antennas, can be more or less disrupted by the boat and its equipment. In order to achieve good radio transmission, it is thus important to position the offset antenna and that of the radio receiver

judiciously. Figure 2 below describes the radio spectrum of the offset antenna. We observe that wave reception is at its maximum perpendicular to the antenna, and lower towards the extremities. Position the outside antenna so that the spectrum covers the deck of your ship as much as possible.

We recommend the optimum configuration of installation below :

- The offset antenna is positioned horizontally and perpendicular to the axis of the boat.
- The offset antenna is placed at the centre of the area where the transmitters are used.
- The cable outlet of the offset antenna must run perpendicular to the antenna, over a length of at least 30cm.
- The receiver housing and its antenna are positioned vertically.

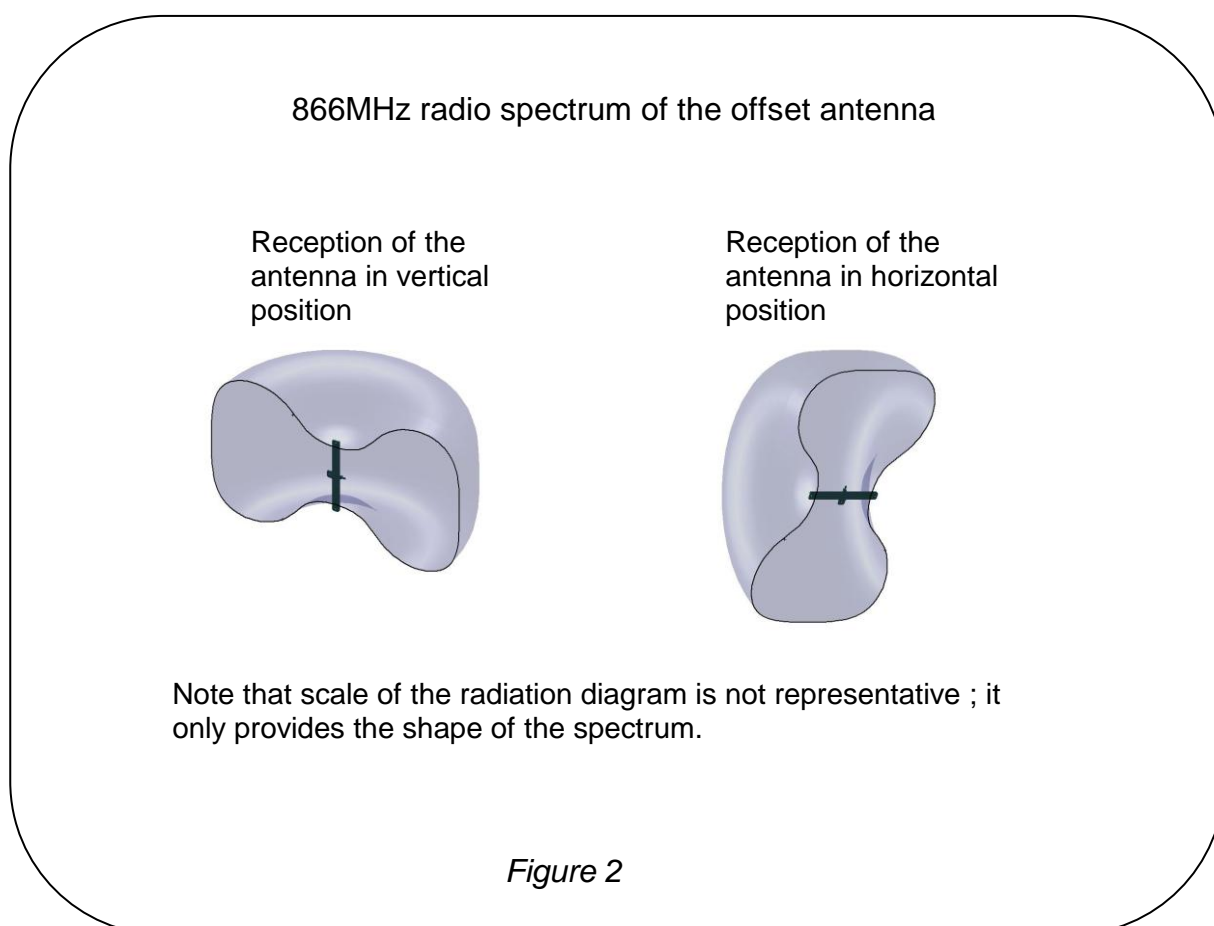

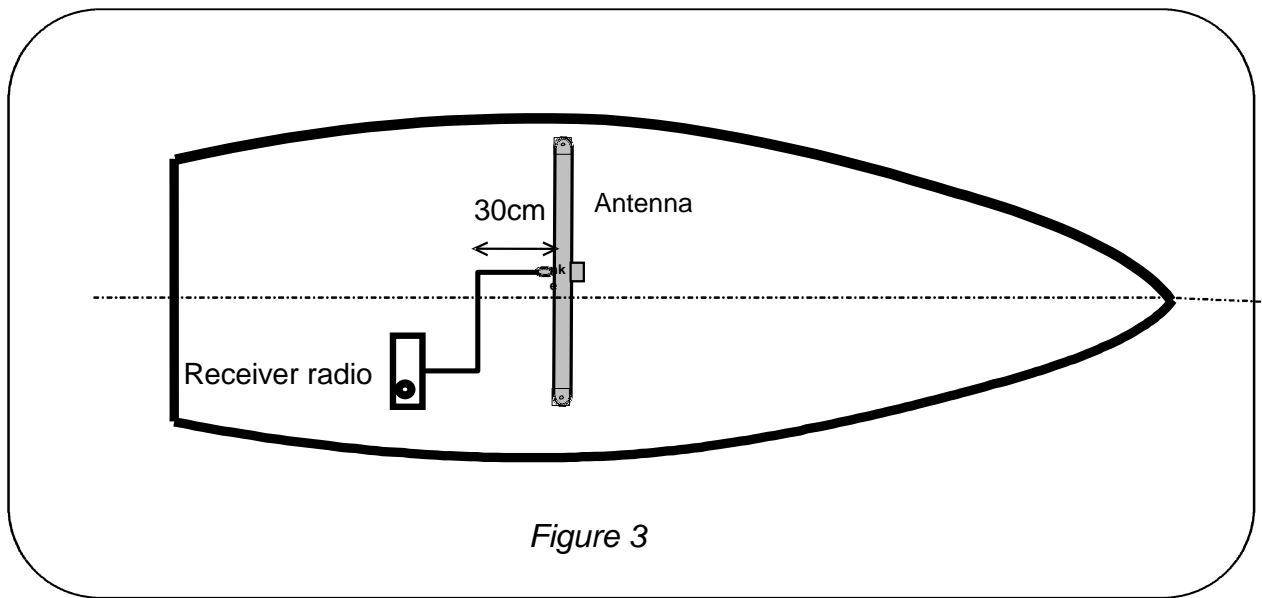

3.4 Specific precautions for boats made with metal and carbon

Boats made with metal (steel, aluminium, etc.) and carbon, are sometimes impervious to radio waves. Thus we recommend that you install the offset antenna outside the hull of the boat. The **radio receiver** must be installed inside.

Moreover, when the mounting wall is made out of metal or carbon, it is necessary to fit an insulant (wood or plastic), at least five centimetre thick, between the antennas, and the mounting wall (see figure 4).

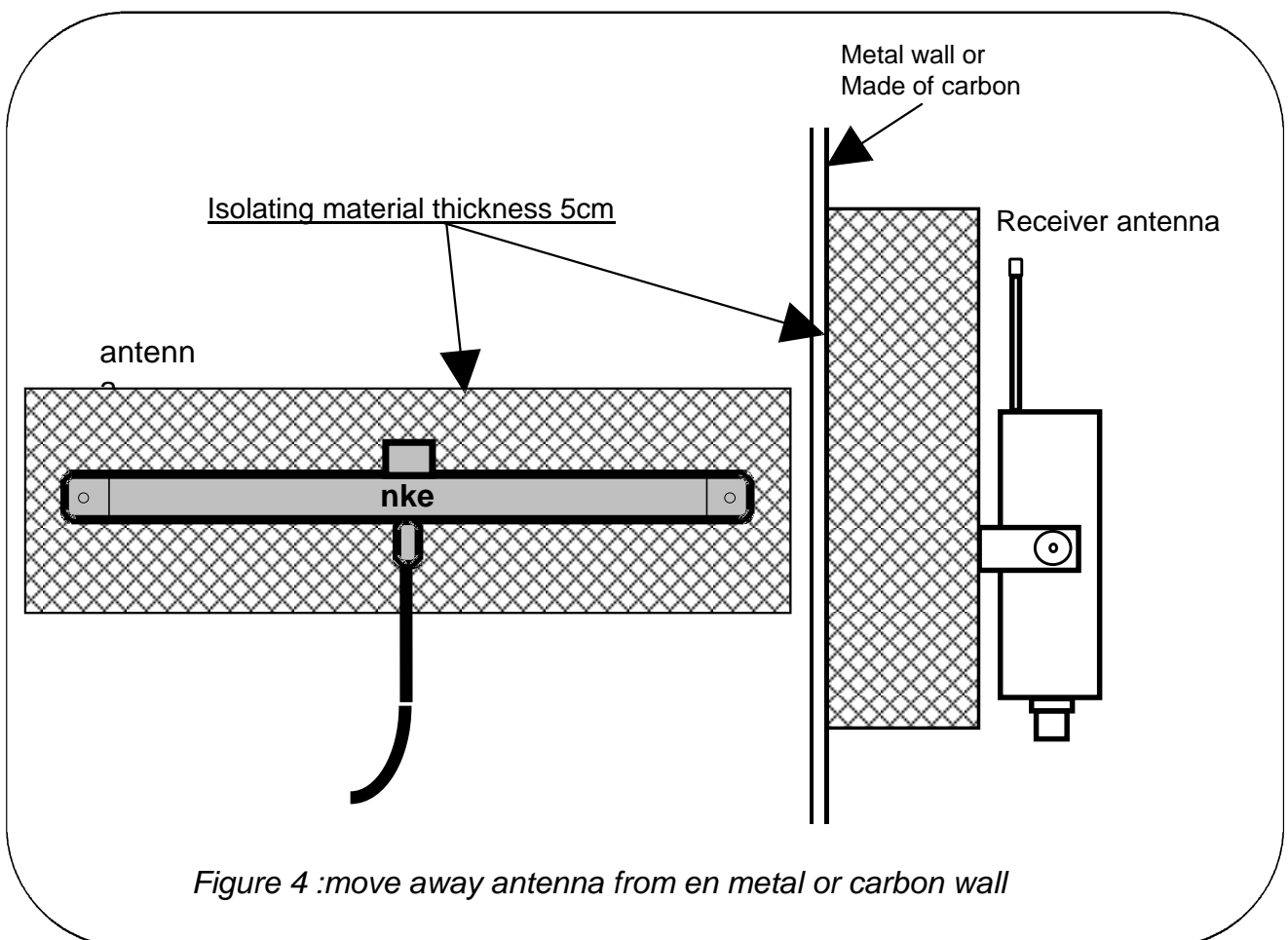

3.5 Position and installation of the radio receiver housing

The receiver housing is non waterproof, and must therefore be placed inside the boat, in a dry and protected place. The receiver is delivered with a mounting bracket. Attach the bracket on the bulkhead with 2 screws of 5 mm diameter (screws not included).

The radio receiver, equipped with a small antenna, must be mounted vertically.

3.6 Checking the radio transmission from the transmitters to the radio receiver

You have determined the locations of the radio receiver and offset antenna. Before fitting them definitively, check the quality of radio reception of your installation. In order to do that, use a **TOPLINE** radio transmitter and check that it controls your instruments, everywhere on the deck of the boat.

4 CONNECTION TO THE TOPLINE BUS AND TO THE NMEA BUS

1. Make the receiver bus cable run to the **TOPLINE** terminal box of your installation.
2. Connect the bus cable inside the terminal box.

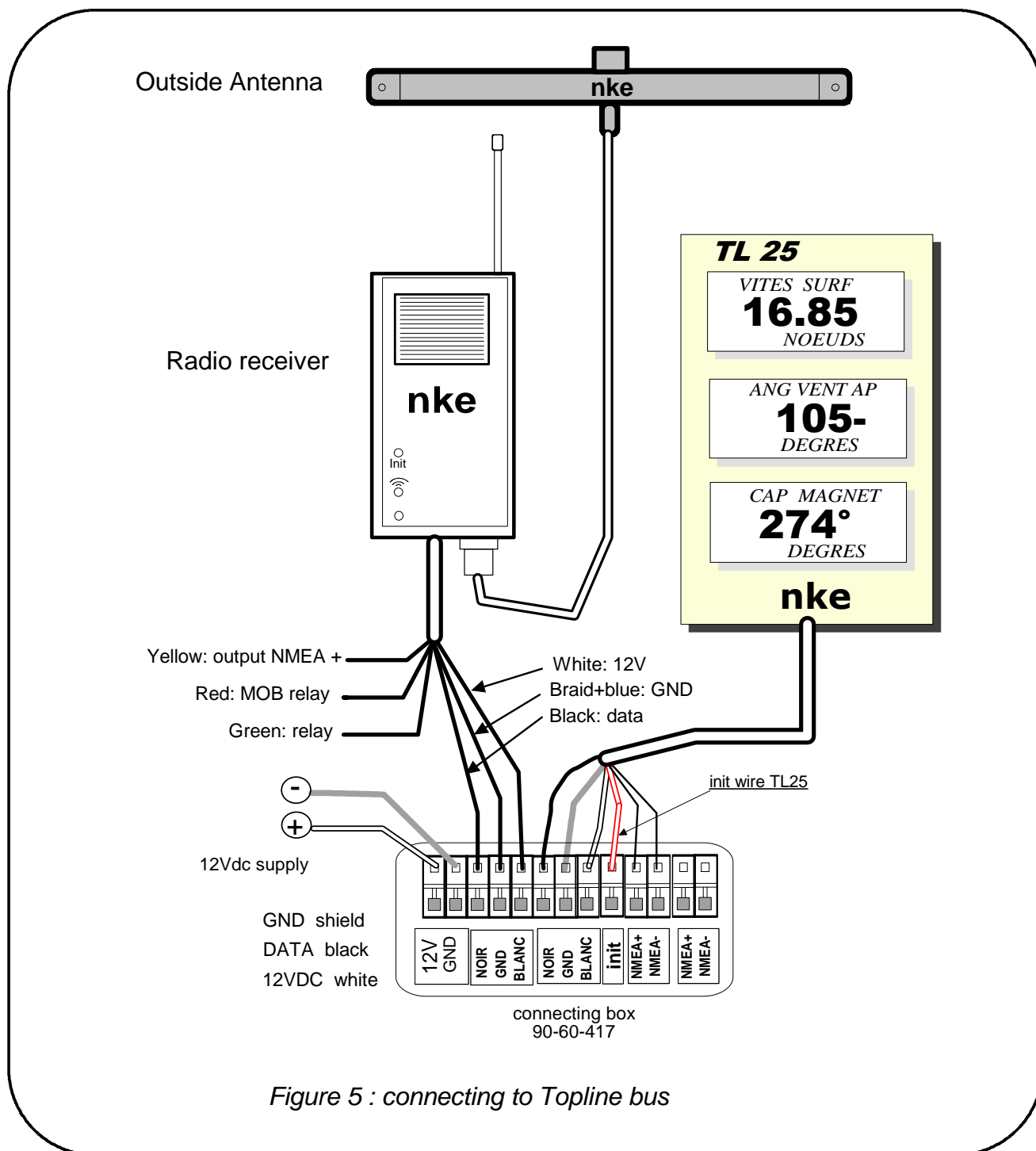

If you reduce the length of the bus cable, strip and galvanise the wires before connecting them inside the terminal box.

CAUTION :

- The connection of the radio receiver must be carried out with the installation power switched off.

Identification of the cable wires

Identification of the receiver cable wires		Topline bus
Coupled braid and blue	Earth common to the Topline bus, the NMEA bus and relay contacts.	Braid
White wire	+12V	White
Black wire	Topline data	Black
Yellow wire	NMEA + output	
Red wire	relay contact man over board alarm	
Green wire	relay contact beacon activation	

4.1 Connection of external relays

Two alarm outputs are available to be used by external relays:

- one of these will activate three minutes after the MOB is initiated
- the other will activate ten minutes after the MOB is initiated

These can be used for various alarms, e.g. to activate a loud horn, to activate a distress beacon or to cut off the power supply to the engine.

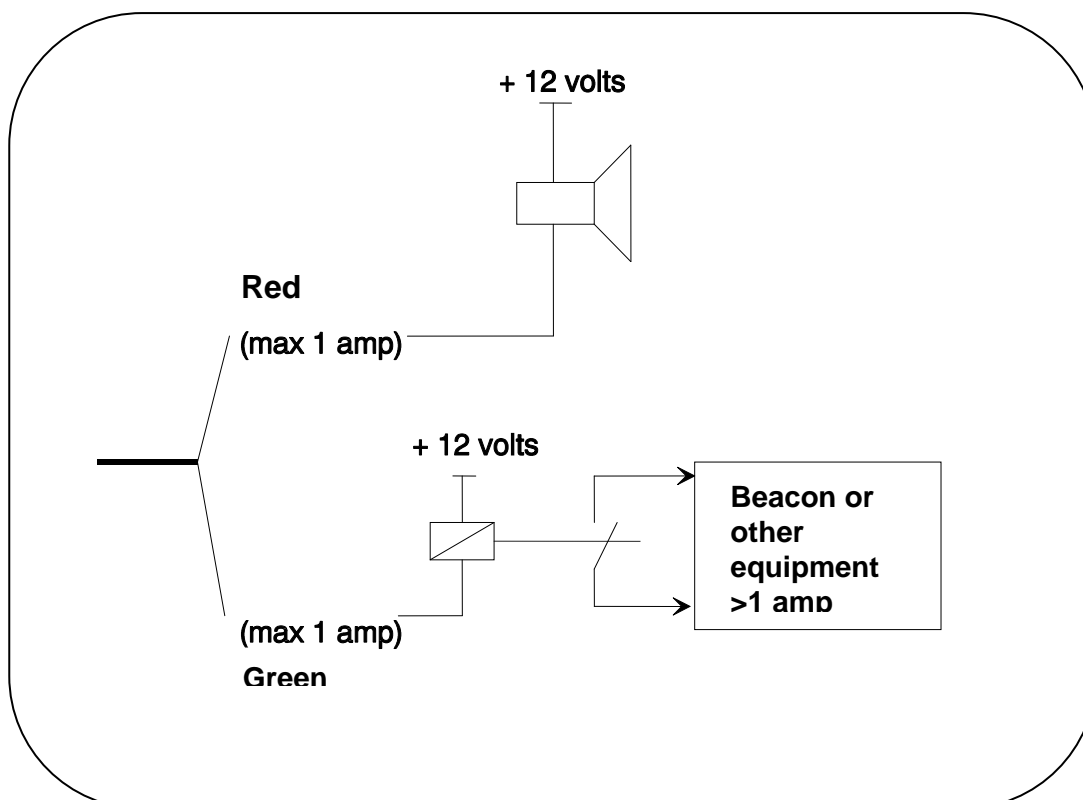

The maximum current carrying capacity of the relay is 1A.

5 RECEIVER INITIALIZATION AND PAIRING OF THE TRANSMITTERS

For the initialization of the radio receiver and transmitter(s) (**Gyropilot**, **Multifunction** and **crew**) at first power-up, you must pair up the transmitter(s) with the **radio receiver**. It will take an address on the bus at this time.

The **radio receiver** is delivered with the address set as **0**. During the initialization, it will automatically insert itself in the list of instruments of the **TOPLINE bus** of your installation, at first free address comprised between **2** and **20**.

5.1 Description of the radio receiver

On the front panel of the **radio receiver**, you will find the « **Init** » push-button. Use a small diameter screwdriver to actuate this push-button.

Underneath, two signal lights indicate the radio receiver status :

- The upper red signal light flickers when the transmitters communicate with the antenna integrated with the receiver. This signal light is permanently on, during the transmitter pairing procedure.
- The bottom red signal light flickers when the transmitters communicate with the outside antenna.

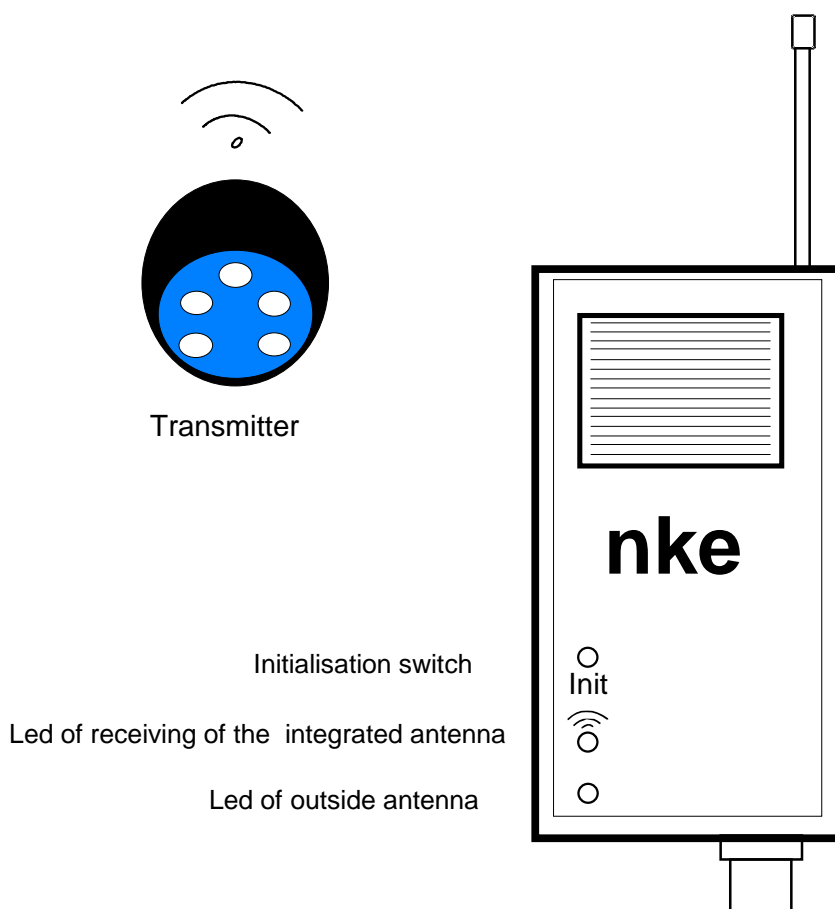

Figure 7 :Radio receiver

5.2 About the pairing

Important :

- All Gyropilot, Multifunction and Crew MOB devices used with an individual radio Receiver must be paired at the same time. The pairing of any single device subsequent to the initial pairings will delete older pairings and they must all be redone.
- The maximum number of devices for a radio receiver to be paired is 8.
- Once you enter the initialization procedure you will need to have all your devices at hand to complete the process.
- Below the procedures for pairing the Gyropilot, Multifunction and Crew MOB devices are detailed.

Caution before you continue !

You must disable the MOB function on the remote radio devices before entering the pairing procedure because the transmission of MOB messages to the receiver can disrupt the pairings.

For the Gyropilot Remote you must press on the **STOP** key of the transmitter until the signal light stays on. When you release the **STOP** key the light will go out and the MOB is disabled.

For the Multifunction Remote you must press on the ◀▶ key until the signal light stays on. When you release the ◀▶ key the light will go out and the MOB is disabled.

With the Crew MOB Transmitter, if the light is blinking you must press the **ON** button until the signal light stays on. When you release the **ON** button the light will go out and the MOB is disabled. If the light is blinking the unit is activated.

5.3 Initialization of the radio receiver

Press the **init** button until the red light signal stays on, release the button and the receiver will start to beep at 1 second intervals.

You now have one minute to start the pairing procedure, at completion of each pairing cycle the receiver will continue to beep for one minute to allow you to pair the next unit.

5.4 Pairing the *Gyropilot* transmitter with the receiver

- 1- Hold down the **STOP** key for three beeps, release the **STOP** key
- 2- Press and release the **STOP** key once
- 3- Hold down the **STOP** key for approximately three beeps, you will hear a long beep if the pairing is successful. You will hear three short beeps if there is a problem with the pairing and you must attempt the pairing again.

To exit the pairing procedure

The pairing procedure will automatically end one minute after the last device is paired or you may press the **init** button to end the procedure at any time.

5.5 Pairing of a *Multifunction* transmitter with the receiver

- 1- Hold down the **ENT** key for three beeps, release the **ENTER** key
- 2- Press and release the **ENT** key once
- 3- Hold down the **ENT** key for approximately three beeps, you will hear a long beep if the pairing is successful. You will hear three short beeps if there is a problem with the pairing and you must attempt the pairing again.

To exit the pairing procedure

The pairing procedure will automatically end one minute after the last device is paired or you may press the **init** button to end the procedure at any time.

5.6 Pairing of a *Crew* transmitter with the receiver

- 1- Hold down the ON/OFF key for three beeps, release the ON/OFF key
- 2- Press and release the ON/OFF key once
- 3- Hold down the **ON/OFF** key for approximately three beeps, you will hear a long beep if the pairing is successful. You will hear three short beeps if there is a problem with the pairing and you must attempt the pairing again

To exit the pairing procedure

The pairing procedure will automatically end one minute after the last device is paired or you may press the **init** button to end the procedure at any time.

5.7 Set an address to the *radio receiver*

This operation allows the *radio receiver* to take an address on the TOPLINE bus :

- After pairing up the transmitter(s), press one of the keys of a transmitter,
- The master display then indicates « **Creating list** » (the other multifunction displays indicate «**List**»).
- an address is assigned to the *radio receiver*, and this address is saved to the memory.

6 DIAGNOSTIC FOR 1ST LEVEL TROUBLESHOOTING.

This chapter can help you rapidly resolve minor problems which do not require the intervention of a specialist. Before contacting technical support, please check the troubleshooting table below.

Problem	Possible causes and solutions
The Topline bus does not detect the radio receiver .	The bus cable is not or is badly connected to the terminal box : check the plugging and the connection inside the terminal box. Check the state of the cables : they must not show any sign of wear or cut.
The radio receiver emits an intermittent audible signal every 5 seconds.	The radio receiver stopped receiving the Topline Bus signal for more than 10 seconds : the bus cable is not or is badly connected to the terminal box : check the plugging and the connection inside the terminal box.
The Multifonction transmitter no longer acts on your displays. The Gyropilot transmitter no longer controls the pilot. The radio system is no longer operating.	- The radio transmitter is powered by a battery. The life time of the battery is 1 to 3 years. It may need to be replaced. - The transmitter is not paired with the radio receiver : perform the pairing of the transmitter (see chapter on initialisation).
The crew transmitter does not trigger the « man over board » alarm.	- The radio receiver and its antenna do not receive the messages from the transmitter. Check that the offset antenna is properly connected to the receiver. Check that the antenna is not located near an object made with metal or carbon.

7 TECHNICAL SPECIFICATIONS



Radio receiver

- Range of the radio system : 25 metre radius.
- Frequency: 868,300 MHz
- Sensibility: -100dBm
- Tightness of the housing : IP20. Non waterproof housing.
- 3 metre cable.
- Weight : 260 g
- Operating temperature : -10°C to +50°C
- Storage temperature : -20°C to +60°C

Offset antenna

- Tightness : IP68
- 6 metre cable fitted with a BNC connector.
- Weight : 270 g
- Operating temperature : -10°C to +50°C
- Storage temperature : -20°C to +60°C

The radio receiver is in compliance with the EMC standards.

DECLARATION OF CONFORMITY <i>DECLARATION DE CONFORMITE</i> R & TTED 99 / 5 / EEC	
	
Manufacturer <i>Fabricant</i>	Micrel – Nke
Address <i>Adresse</i>	ZI de Kerandre Rue Gutenberg 56700 Hennebont France
Declare that the product <i>Déclarons que le produit</i>	
Name <i>Nom</i>	Universal Radio Receiver Récepteur radio universel
Reference <i>Référence</i>	90-60-250
Frequency <i>Fréquence</i>	868.300 MHz
Meets the essentials requirements according to article 3 of the following EC-Directive: <i>Est conforme aux exigences essentielles de l'article 3 de la Directive CE :</i>	
Directive 1999 / 5 / EC of the European Parliament and the council of 9 March 1999 on radio equipment and telecommunications terminal equipment and the mutual recognition of their conformity.	
Directive 1999 / 5 / CE du Parlement Européen et du Conseil du 9 Mars 1999 concernant les équipements hertziens et les équipements terminaux de télécommunications et la reconnaissance mutuelle de leur conformité.	
And that the following harmonised standards have been applied: Et que les standards harmonisés ont été appliqués :	
ETSI EN 300220 – 3 : 2000	
HENNEBONT <i>03-12-18</i> <small>Date & location / Date et lieu</small>	 Jean Pierre MAQUAIRE – CEO / P.D.G

NOTES
